

AIRMATIC®
WE'LL HANDLE IT.

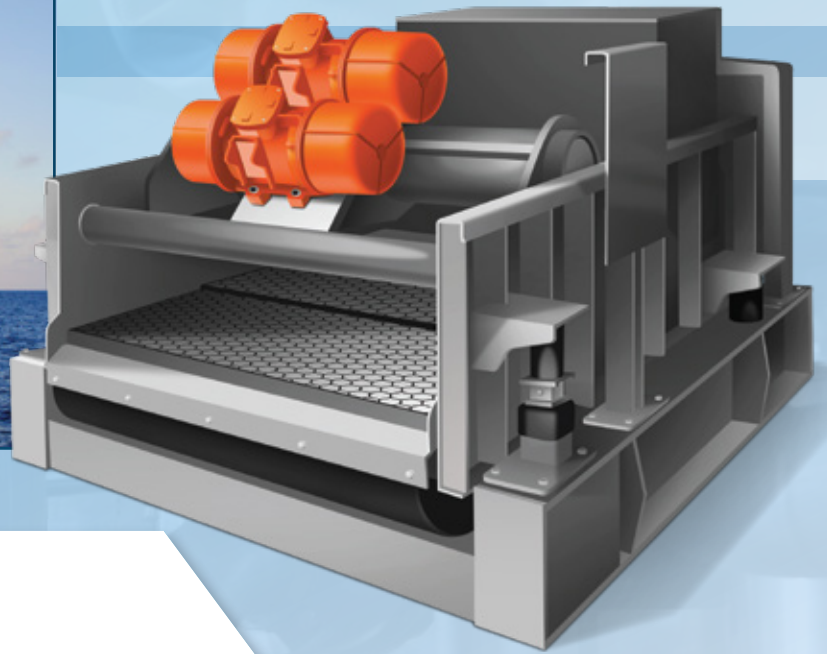

VIBRATORY MOTORS & DRIVES

OIL & GAS DRILLING

Vibratory Motors for the Oil & Gas Industry

AIRMATIC
284 Three Tun Rd. Malvern, PA 19355
215.333.5600
infocenter@airmatic.com
airmatic.com

Maximize uptime while minimizing cost when purchasing an off-the-shelf replacement **Vibratory Motor for your Feeders, Separators, Sifters, Screeners, Classifiers, Shakers, Drums** and other **Vibratory Equipment** with Vibrator Motors from **AIRMATIC**. There is no longer a need to go back to the original equipment manufacturer for an expensive (both cost and lead time) replacement vibrator when you can buy an exact replacement Vibratory Drive directly from **AIRMATIC – North America's leading vibrator distributor**.

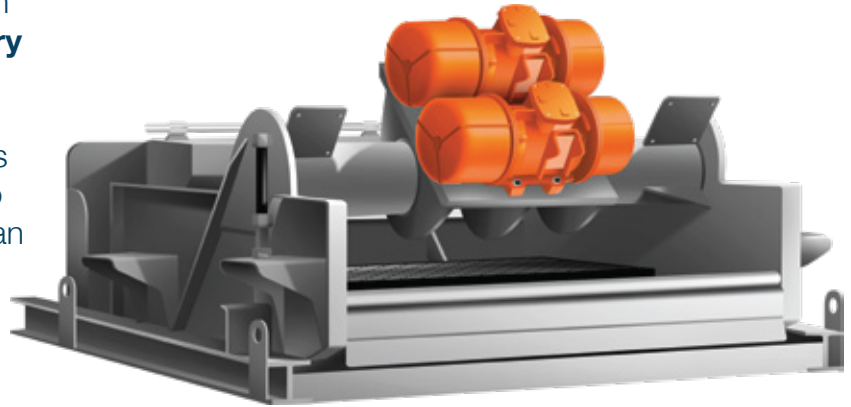

OUR PRODUCTS

AIRMATIC stocks the nation's largest inventory of Foot-Mount Vibrator Motors used by most manufacturers of Feeders & Conveyors, Shakeouts, Screeners, Densifiers & De-aers, Classifiers, Separators, Sifters, and Settlers & Compactors, and we are a service center for most vibrator manufacturers.

AIRMATIC also stocks and services Vertical-Mount Vibrator Motors that are fully interchangeable with any Vibrator used on standard 48" and 60" Round Separator Machines made by the leading manufacturers of vibratory equipment.



TECHNICAL SUPPORT

Need technical support or application assistance to solve a problem with your existing vibratory equipment or in selecting new equipment? Let our Consultants help. We have over 30 years' experience in vibratory equipment selection and troubleshooting, and because we don't represent any vibratory equipment manufacturers, we can provide expert and impartial recommendations.

VIBRATOR REPAIR

If a Vibrator Motor needs repair, contact **AIRMATIC at 800.332.9770**. Most electric motor repair shops are not trained to repair industrial Electric Vibrator Motors. We recommend that they be returned to our Malvern, PA Service Center. Attempting to repair Electric Vibrator Motors in-house or by a non-qualified repair shop – including bearing replacement – will void the manufacturer's warranty.

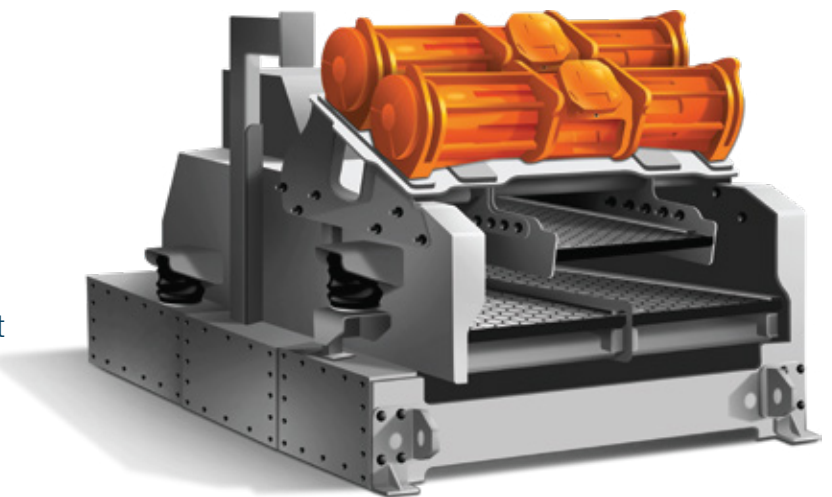

SHALE SHAKER VIBRATORY MOTORS

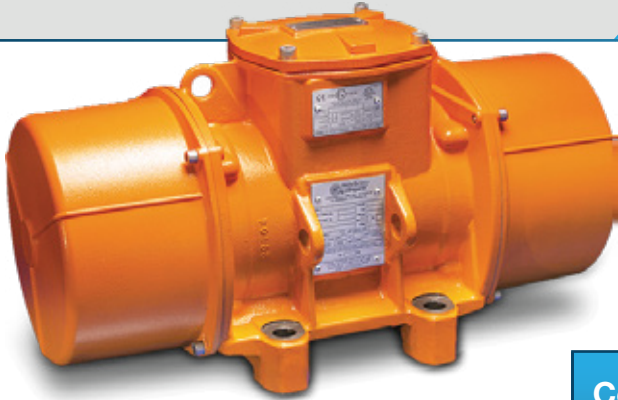

CDX-12 6 POLES
1000 RPM @ 50Hz
1200 RPM @ 60Hz

Model	Frame Size	Type	Centrifugal Force LBF		Power Output		Bolt Pattern	
			50 Hz	60 Hz	50 Hz	60 Hz	D	E
CDX 12-1630	35	U	66	96	0.29	0.31	4.72	6.69
CDX 12-1990	40	U	171	167	0.50	0.59	5.51	7.48
CDX 12-2530	50	U	215	246	0.65	0.73	5.51	7.48
CDX 12-3410	60	U	769	471	0.99	1.22	6.61	8.86
CDX 12-6050	70	U	906	904	1.97	1.97	6.1	10.04
CDX 12-8450	80	U	1214	1302	2.28	2.48	7.09	11.02
CDX 12-45000	110	U	1584	1672	15.8	19.7	5.51	20.74

ALL CDX MODELS ARE EXPLOSION PROOF

■ TYPE U

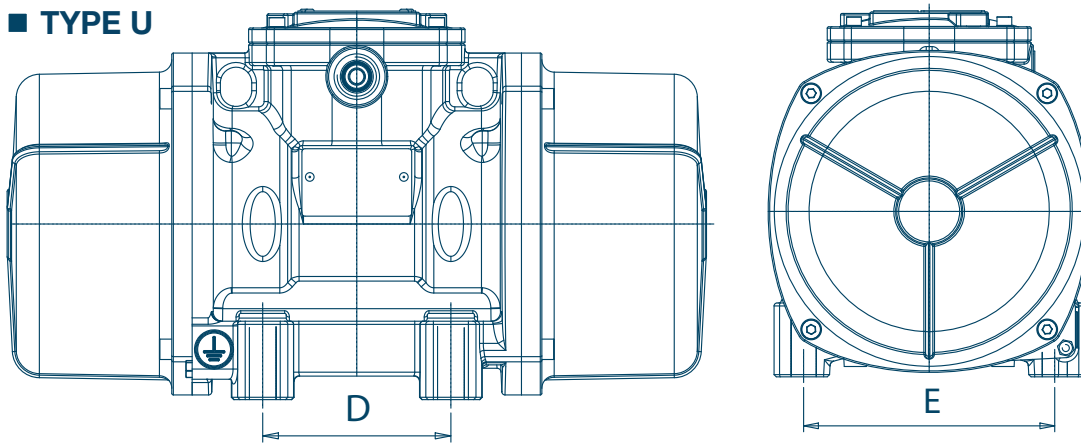

Request Spec Sheet for Complete Dimensional Data

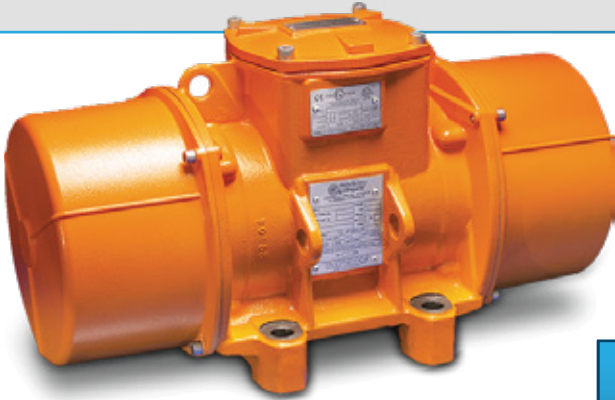

CDX-18

4 POLES
1500 RPM @ 50Hz
1800 RPM @ 60Hz

Model	Frame Size	Type	Centrifugal Force LBF		Power Output		Bolt Pattern	
			50 Hz	60 Hz	50 Hz	60 Hz	D	E
CDX 18-2150	35	U	2299	2160	0.49	0.59	4.72	6.69
CDX 18-3190	40	U	3109	3188	0.73	0.99	5.51	7.48
CDX 18-3850	50	U	3956	3865	1.2	1.5	5.51	7.48
CDX 18-4400	50	U	4519	4473	1.2	1.5	5.51	7.48
CDX 18-5100	50	U	5566	5324	1.2	1.5	5.51	7.48
CDX 18-5380	60	U	5324	5377	1.7	2.0	6.1	8.86
CDX 18-5900	60	U	5900	5900	1.7	2.0	6.1	8.86
CDX 18-8300	70	U	8448	8237	2.5	2.5	6.1	10.04
CDX 18-10900	70	U	11015	10870	2.8	2.8	7.09	11.02

ALL CDX MODELS ARE EXPLOSION PROOF

■ TYPE U

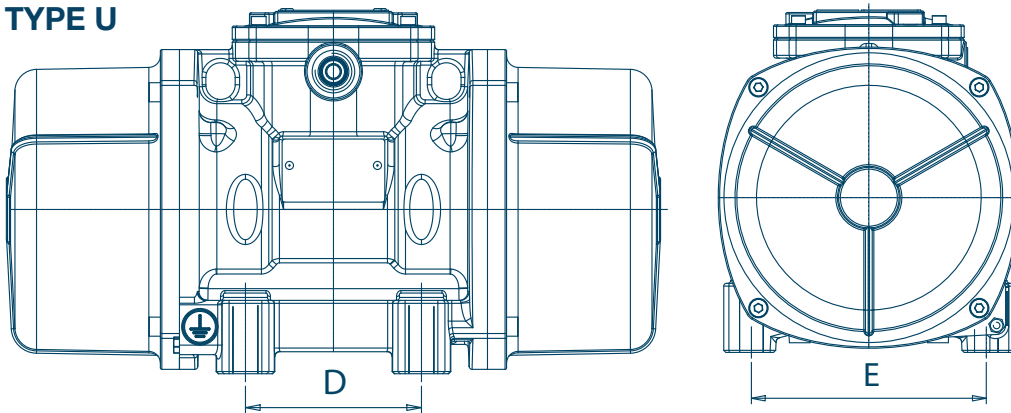

Request Spec Sheet for Complete Dimensional Data

SHALE SHAKER VIBRATORY MOTORS



IMX-12 6 POLES 1000 RPM @ 50Hz 1200 RPM @ 60Hz

Model	Frame Size	Type	Centrifugal Force LBF		Power Output		Bolt Pattern	
			50 Hz	60 Hz	50 Hz	60 Hz	D	E
IMX 12-1990	40	MX	1780	1991	0.50	0.59	2.95	7.28
IMX 12-2530	50	MX	2490	2532	0.65	0.73	5.91	7.28
IMX 12-3410	60	MX	3604	3408	0.99	1.22	3.15	8.27
IMX 12-6050	70	MX	5722	6043	1.97	1.97	3.35	10.63
IMX 12-8450	80	MX	8417	8428	2.28	2.28	4.87	12.01

ALL IMX MODELS ARE EXPLOSION PROOF

■ TYPE MX

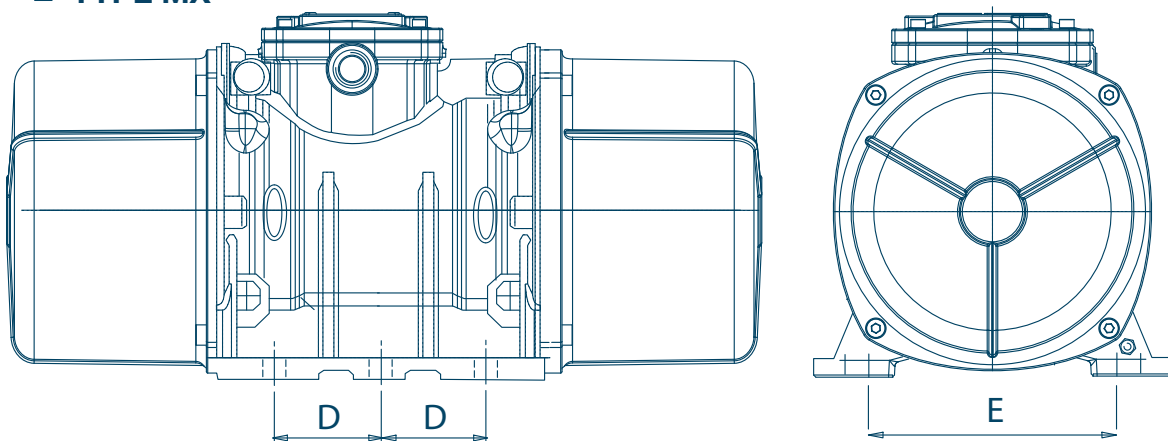

Request Spec Sheet for Complete Dimensional Data



AIRMATIC

airmatic.com | 215.333.5600 | infocenter@airmatic.com



IMX-18

4 POLES
1500 RPM @ 50Hz
1800 RPM @ 60Hz

Model	Frame Size	Type	Centrifugal Force LBF		Power Output		Bolt Pattern	
			50 Hz	60 Hz	50 Hz	60 Hz	D	E
IMX 18-3190	40	MX	3109	3188	0.73	0.99	2.95	7.28
IMX 18-3850	50	MX	3956	3864	1.2	1.5	5.91	7.28
IMX 18-4400	50	MX	4519	4473	1.2	1.5	5.91	7.28
IMX 18-5100	50	MX	5566	5324	1.2	1.5	5.91	7.28
IMX 18-5380	60	MX	5324	5377	1.7	2.0	3.15	8.27
IMX 18-5900	60	MX	5900	5900	1.7	2.0	3.15	8.27
IMX 18-8300	70	MX	8448	8237	2.5	2.5	3.35	10.63
IMX 18-10900	80	MX	10870	1080	2.8	2.8	4.87	12.01

ALL IMX MODELS ARE EXPLOSION PROOF

■ TYPE MX

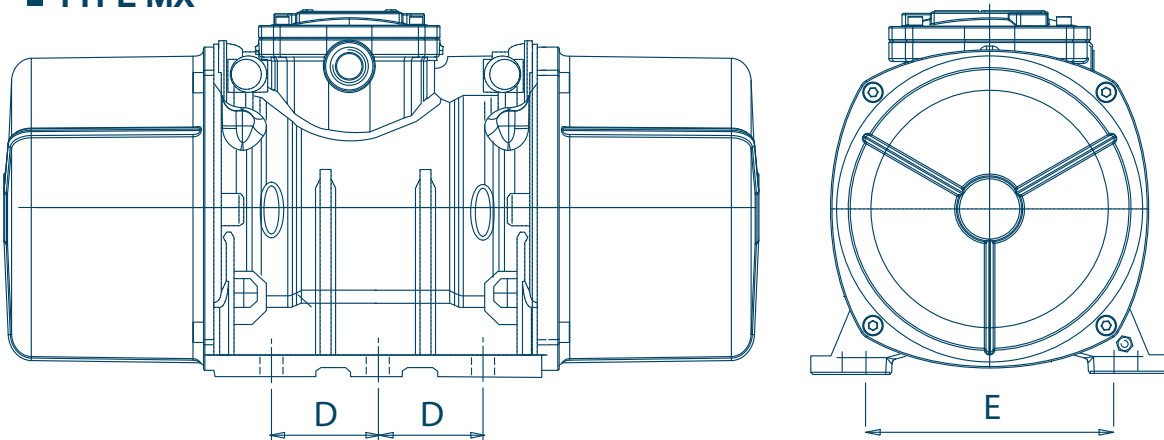

Request Spec Sheet for Complete Dimensional Data

SHALE SHAKER VIBRATORY MOTORS

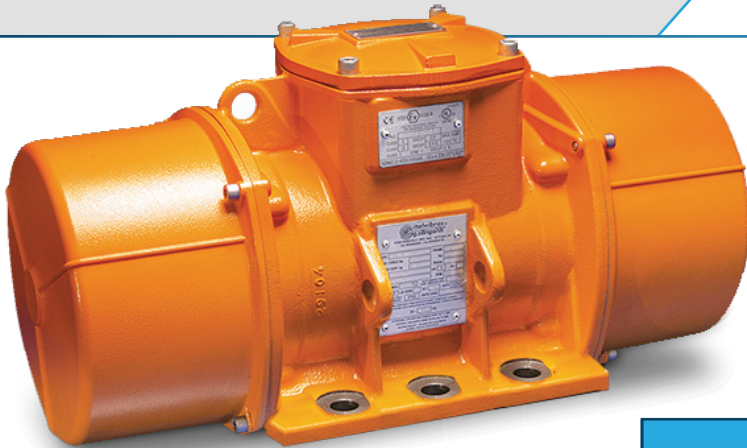

VMX-12 6 POLES 1000RPM @ 50Hz 1200RPM @ 60Hz

Model	Frame Size	Type	Centrifugal Force LBF		Power Output		Bolt Pattern	
			50 Hz	60 Hz	50 Hz	60 Hz	D	E
VMX 12-1990	40	MX	1780	1991	0.50	0.59	2.76	6.69
VMX 12-2530	50	MX	2490	2532	0.65	0.73	5.51	6.69
VMX 12-3410	60	MX	3604	3408	0.99	1.22	3.27	9.02
VMX 12-5100	60	MX	-	5177	-	1.22	3.27	9.02
VMX 12-6050	70	MX	5722	6043	1.97	1.97	4.13	9.76
VMX 12-8200	70	MX	-	8247	-	1.97	4.13	9.76
VMX 12-8450	80	MX	8417	8428	2.28	2.48	4.63	11.02

ALL VMX MODELS ARE EXPLOSION PROOF

■ TYPE MX

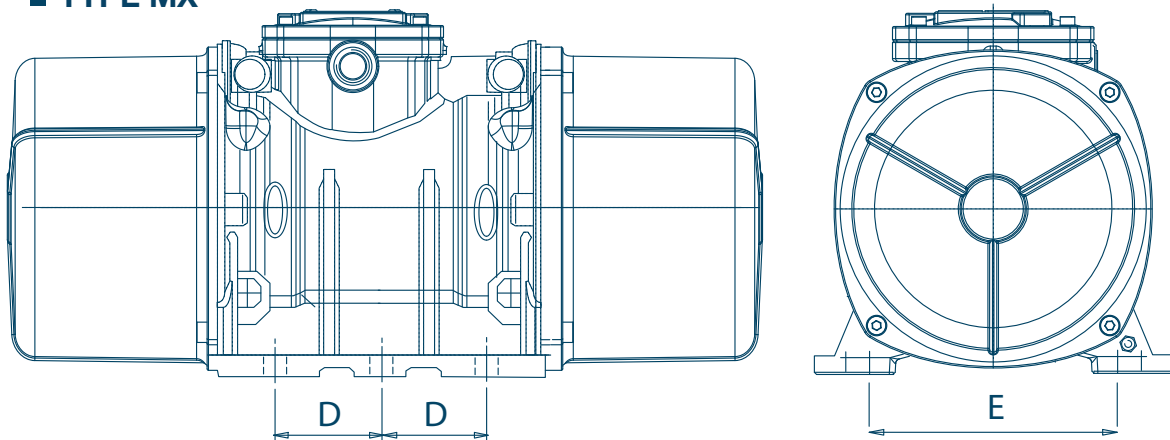

Request Spec Sheet for Complete Dimensional Data



VMX-18

4 POLES
1500 RPM @ 50Hz
1800 RPM @ 60Hz

Model	Frame Size	Type	Centrifugal Force LBF		Power Output		Bolt Pattern	
			50 Hz	60 Hz	50 Hz	60 Hz	D	E
VMX 18-3190	40	MX	3109	3188	0.73	0.99	2.76	6.69
VMX 18-3850	50	MX	3956	3865	1.2	1.5	5.51	6.69
VMX 18-4400	50	MX	4519	4473	1.2	1.5	5.51	6.69
VMX 18-5100	50	MX	5566	5324	1.2	1.5	5.51	6.69
VMX 18-5380	60	MX	5324	5377	1.7	2.0	3.27	9.02
VMX 18-5900	60	MX	5900	5900	1.7	2.0	3.27	9.02
VMX 18-8300	70	MX	8448	8237	2.5	2.5	4.13	9.76
VMX 18-10900	80	MX	11015	10870	2.8	2.8	4.63	11.02

ALL VMX MODELS ARE EXPLOSION PROOF

■ TYPE MX

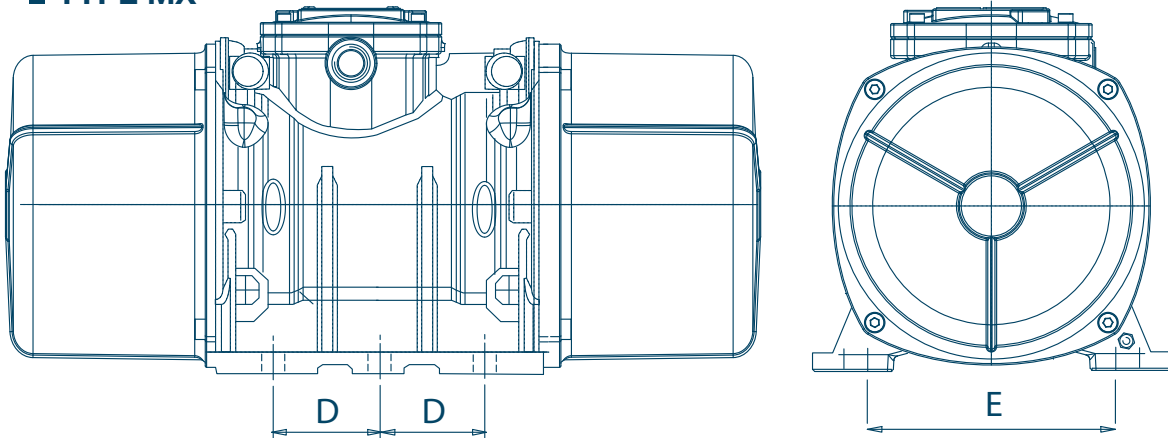

Request Spec Sheet for Complete Dimensional Data

TECHNICAL FEATURES CDX-G, IMX-G, VMX-G

Power Supply - Three-phase voltage up to 690V (maximum 600V for UL and CSA), 50Hz or 60Hz (fixed) or 20 to 70Hz (variable). Suitable for use with a Variable Frequency Drive from 20Hz to the base frequency with constant torque load profile.

Polarity - 4 poles typical. 2, 6 and 8 poles also available.

QC/QA Process - Components that affect protection mode are 100% accurately controlled and results are recorded for complete traceability.

Motor Duty Cycle - Service Factor 1.15. Continuous service (S1) at maximum declared centrifugal force and electric power (rating). Intermittent services are also possible depending on vibrator type and operating conditions. For detailed information, consult AIRMATIC Technical Support.

Centrifugal Force - Range up to 49250 lb. (220 KN), with centrifugal force adjustable from 0 to 100%.

Mechanical Protection - IP66 according to IEC 529, EN 60529.

Mechanical Impact Protection - IK 08 according to IEC 68, EN 50102.

Insulation Class - EU Class F: 311°F (155°C).

Tropicalization - Standard on all Vibrators, with vacuum encapsulation up to size 35, with "drop by drop" trickle system for larger sizes.

Ambient Temperature Ratings - From 14°F to 131°F (-10°C to 55°C).

Thermal Protection - Not required. Thermostat or thermistor control circuits provided on request.

Vibrator Mounting - In all positions and therefore without restriction.

Lubrication - All Vibrators are lubricated at factory. Periodic re-lubrication recommended for size 40 and larger.

Terminal Box - Large fixed electrical connections. HD terminal cover (increased thickness) is built to contain internal explosions. Special shaped terminals enable power supply cable to be secured against loosening.

Design - Three-phase asynchronous type. Designed for maximum starting torques and torque specific to requirements of vibratory equipment. Insulated windings use vacuum encapsulation for size 35; use "drop by drop" trickle system with Class H resin for larger sizes. Rotor is die cast aluminum.

Housing Construction - Ductile cast iron for larger sizes. Patented shape improves heat dispersion and lowers normal running temperature at full load. External grounding screw is located on housing as required by IEC/EN 60079-0 regulation.

Bearing Flange - Constructed in grey cast iron. Geometry of flange uniformly transmits load to the housing uniformly.

Bearings - Custom built to meet the unique speed, high radial and axial forces, and loads imposed by Vibratory Motors.

Motor Shaft - Treated steel Alloy (isothermic hardening) resistant to stress.

Eccentric Weights - Eccentric Weight (fixed; adjustable; reversing,) can be supplied based on Customer Requirements.

Weight Covers - In aluminum alloy. Special coatings provided on request. Also available in stainless steel.

Substrate Coating - Electrostatic surface treatment using polymerized epoxy polyester powder cured to 200°C. Tested in salt spray for 500 hours.

Note: Vibrators available with different mount bolt patterns to interchange with any manufacturer model motors.

Certifications



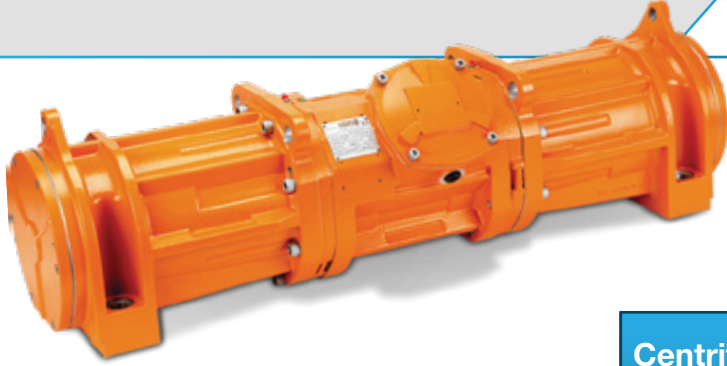

MVTX-18

4 POLES
1500 RPM @ 50Hz
1800 RPM @ 60Hz

Model	Frame Size	Type	Centrifugal Force LBF		Power Output		Bolt Pattern		
			50 Hz	60 Hz	50 Hz	60 Hz	D	D1	E
MVTX 18-7700	70	MVTX FS70	7590	7700	2.5	2.5	37.76	-	8.996
MVTX 18-10900	80	MVTX FS80	11015	11051	3.5	3.5	-	*	-
MVTX 18-17500	90	MVTX FS90	17446	17446	4.3	4.7	-	*	-

Request Spec Sheet For Additional Dimensions

* Different Mounting Bolt Patterns Available

ALL MVTX MODELS ARE EXPLOSION PROOF

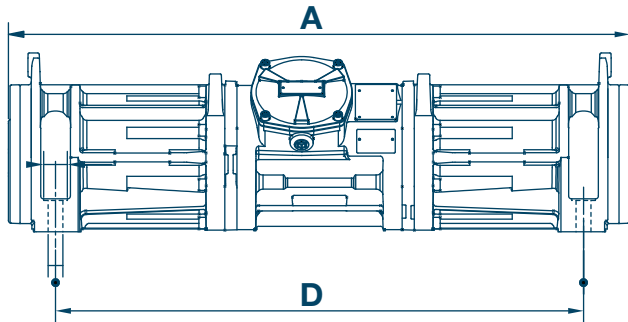

■ MVTX FS70

■ MVTX FS80

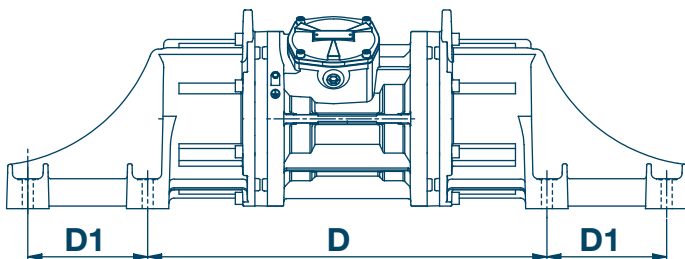
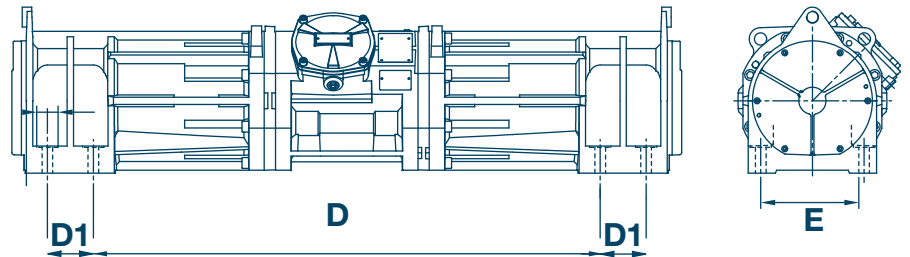

■ MVTX FS90

MVTX-G TECHNICAL FEATURES

Power Supply - Three-phase voltage up to 690V (maximum 600V for UL and CSA), 50Hz or 60Hz (fixed) or 20 to 70Hz (variable). Suitable for use with a Variable Frequency Drive from 20Hz to the base frequency with constant torque load profile.

Polarity - 4 poles typical. 2, 6 and 8 poles also available.

QC/QA Process - Components that affect protection mode are 100% accurately controlled and results are recorded for complete traceability.

Motor Duty Cycle - Service Factor 1.15. Continuous service (S1) at maximum declared centrifugal force and electric power (rating). Intermittent services are also possible depending on vibrator type and operating conditions. For detailed information, consult AIRMATIC technical support.

Centrifugal Force - Range up to 17450 lb. (78 KN), with centrifugal force adjustable with hand tools to improve Screen Performance.

Mechanical Protection - IP66 according to IEC 529, EN 60529.

Mechanical Impact Protection - IK 08 according to IEC 68, EN 50102.

Insulation Class - EU Class F: 311°F (155°C).

Tropicalization - Standard on all Screen Vibrators with "drop by drop" trickle system.

Ambient temperature - From 14°F to 131°F (-10°C to 55°C).

Thermal Protection - Not required. Thermostat or thermistor control circuits provided on request.

Vibrator Mounting - Typical horizontal.

Lubrication - Vibrators lubricated at factory. Periodic re-lubrication recommended.

Terminal Box - Large fixed electrical connections. HD Terminal Cover (increased thickness) is built to contain internal explosions. Special shaped terminals enable power supply cable to be secured against loosening.

Design - Three-phase asynchronous type. Designed for maximum starting torques and torque curves specific to requirements of vibratory equipment. Insulated windings use the "drop by drop" trickle system with Class H resin. Rotor is die cast aluminum.

Housing Construction - Three parts. Central housing in aluminum, outer housings in aluminum, except for FS90 for which the external part are ductile cast iron. An external grounding screw is located on housing as required by IEC/EN 60079-0 regulation.

Bearing Flange - Constructed in grey cast iron. Geometry of flange uniformly transmits load to the housing.

Bearings - Custom built to meet the unique speed, high radial and axial forces, and loads imposed by Vibratory Motors.

Motor Shaft - Treated Steel Alloy (isothermic hardening) resistant to stress.

Eccentric Weights - Eccentric Weight (fixed; adjustable; reversing,) can be supplied based on Customer Requirements.

Weight Covers - Aluminum Alloy.

Substrate Coating - Electrostatic surface treatment using polymerized epoxy polyester powder cured to 200°C. Tested in salt spray for 500 hours.

Note: Vibrators available with different mount bolt patterns to interchange with any manufacturer model motors.



Certifications

AIRMATIC®

WE'LL HANDLE IT.

AIRMATIC founded in 1944, is a woman-owned Industrial Distributor, with installation and maintenance capabilities, offering equipment, machinery, and shop supplies to the Industrial, Construction, Utility, Government, and Commercial Markets. Our products and services are sold through three business units:

The **MATERIALS MANAGEMENT GROUP** provides products and services to industries that convey, store, transport, and process powders and bulk solids from aggregates, cement, and chemicals to foods, grains, metals, power generation, and waste water treatment applications;

The **SERVICE GROUP** provides fabrication, installation, and maintenance services to improve bulk materials handling efficiency; mechanical clean-out services for silos and hoppers to eliminate material flow problems; and shop repair/rebuilding and modifications services of products sold by the Company.

The **TOOL GROUP** provides power tools, personal protective equipment, materials-handling equipment, shop equipment and MRO supplies used for production, fabrication, assembly, metal removal, maintenance, and storage in manufacturing, construction, utility, and commercial applications. Our Customers tell us that by choosing **AIRMATIC** to solve their problems, they gain increased productivity, decreased costs, and a safer, cleaner work environment.

AIRMATIC

284 Three Tun Rd. Malvern, PA 19355

215.333.5600

infocenter@airmatic.com

airmatic.com