

AIRMATIC®

WE'LL HANDLE IT.

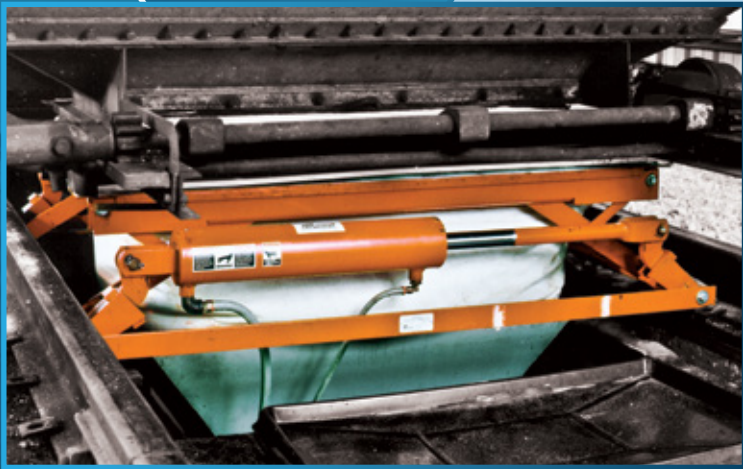

martin®

RAILCAR UNLOADING

Hopper Railcar Unloading Site Solutions

AIRMATIC

284 Three Tun Rd. Malvern, PA 19355

215.333.5600

infocenter@airmatic.com

airmatic.com



Table of Contents

- 4 **Boot-Lift[®] Railcar Connector**
- 12 **Martin Railcar Opener**
- 14 **Martin Railcar Vibrators**

IMPROVING SAFETY AND EFFICIENCY

Unloading bulk materials from railcars is often a difficult, “dirty” job. It can be slow, labor-intensive, messy, noisy and unsafe.

PROCEDURES CAN BE RISKY

Unloading requires workers to go underneath the car to connect the outlet to the under-track conveying system.

SLOW FLOW IS COSTLY

The material—compacted by miles of rail travel—hangs up in the cars, slowing the flow and lengthening the process.

LOST MATERIAL IS COSTLY

When the material is moving, it is exposed to the elements, becoming contaminated or escaping into the environment.

BOOT-LIFT® Railcar Connector

Air-powered connector safely and cleanly funnels material from railcar to the under-track conveying system.



BOOT: SBL-30B0
LIFT: SBL-30S0110



BOOT: SBL-24H0
LIFT: SBL-24S0110



BOOT: SBL-30GB0
LIFT: SBL-30S0110



BOOT: DBL-18B1
LIFT: DBL-18S0101

Installed between the tracks, Boot-Lift Connectors form the link between the railcar and a plant's under-track conveying system. Powered by an air-over-hydraulic system, the unloading boots rise to the gates for clean, efficient and safe unloading of bottom discharge hopper cars. By funneling material to the under-track system, Boot-Lift Railcar Connectors prevent material from being blown away by wind while eliminating the safety hazard of requiring workers to crawl under the car.

Boots automatically connect to and rise with railcar as it empties, maintaining an effective seal.

Unit uses only 1 cfm at 90 psi (28 L/min at 6.2 bar).

Easily and safely operated by remotely located control console.

Models available to suit any car, including double- or single-opening, round-opening and GATX.

Adapter Sheets and Transition Funnels allow interchangeability (see accessories on opposite page).

When working with a combination of both single and double-gate railcar hoppers, select DBL Assemblies with a Transition Funnel and Transition Adapter Sheet in order to accommodate both single and double-gate hoppers.



BOOT-LIFT Manual Aligner
P/N 17326 | Tech Data Sheet 17326

Simplifies car positioning by allowing adjustment of the Boot-Lift Railcar Connector up to six inches (152 mm) total—three inches (76 mm) in either direction—along the track.



BOOT-LIFT Pneumatic Aligner
P/N 34140 | Tech Data Sheet 34140

Air-powered aligner provides eight inches (203 mm) of total adjustment—four inches (102 mm) in either direction—along the track. Remote control operation requires only 10 psi (0.7 bar) of air.

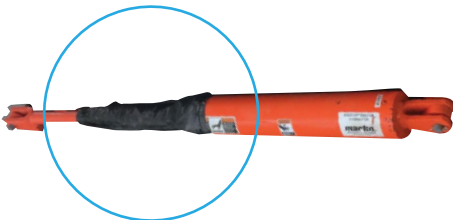

BOOT-LIFT Cylinder Covers
Lift cylinder cover P/N 18335 | Spread cylinder cover P/N 18331



Rugged vinyl-covered cloths prevent damage and contamination of air cylinders from material buildup and environmental conditions.





BOOT-LIFT Funnel Covers
SBL-24 standard P/N 19544 | stainless steel P/N 19544-SS
SBL-30 standard P/N 34884-CA | stainless steel P/N 34884-CAC
DBL-18/DBLG-18 standard P/N 18420 | stainless steel P/N 18420-C

**SBL ASSEMBLIES IDEAL FOR:
SINGLE GATE HOPPER**



SBL BOOT-LIFT[®] ASSEMBLY		
the width (parallel to the rails) of the largest hopper gate is		
 24 INCHES OR LESS	OR	 24 TO 34 INCHES
MODEL # SBL-24		MODEL # SBL-30

THE TYPE OF CARGO BEING UNLOADED

FOOD-GRADE  	OR	CORROSIVE  	OR	STANDARD 
---	----	--	----	--

CHOOSE THE FOLLOWING FEATURES



White Paint	Gray Pain	Orange Paint
Stainless Funnel	Stainless Funnel	Painted Funnel
HDPE Adapter Sheet with Wrapped Foam	HDPE Adapter Sheet with Wrapped Foam	Standard Wood Adapter Sheet
Food-Grade Boot	Black Vinyl Boot	Black Vinyl Boot

THE FOLLOWING FEATURES ARE OPTIONAL



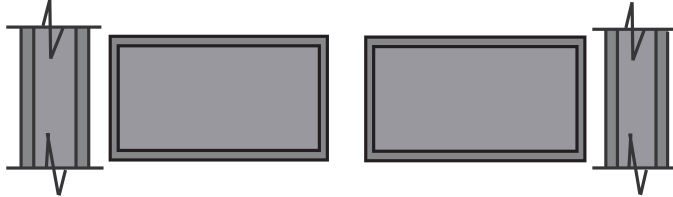

Aligner w/FDA Paint	Aligner w/Steel-IT Paint	Standard Aligner
Stainless Funnel Cover	Stainless Funnel Cover	Standard Funnel Cover

**DBL ASSEMBLIES IDEAL FOR:
DOUBLE GATE HOPPER**



DBL BOOT-LIFT[®] ASSEMBLY		
TYPE OF RAILCAR		
 STANDARD MODEL # DBL-18	OR	 GATX MODEL # DBLG-18

THE TYPE OF CARGO BEING UNLOADED

FOOD-GRADE  	OR	CORROSIVE  	OR	STANDARD 
---	-----------	--	-----------	--

CHOOSE THE FOLLOWING FEATURES

White Paint	Gray Pain	Orange Paint
Stainless Funnel	Stainless Funnel	Painted Funnel
Food-Grade Boot	Black Vinyl Boot	Black Vinyl Boot

THE FOLLOWING FEATURES ARE OPTIONAL

Aligner w/FDA Paint	Aligner w/Steel-IT Paint	Standard Aligner
Stainless Funnel Cover	Stainless Funnel Cover	Standard Funnel Cover

When working with a combination of single and double-gate railcar hoppers, select DBL Assemblies with a Transition Funnel and Transition Adapter Sheet in order to accomodate both single and double-gate hoppers.

SINGLE-OPENING ASSEMBLIES FOR SINGLE-GATE HOPPERS

SBL-24/-30

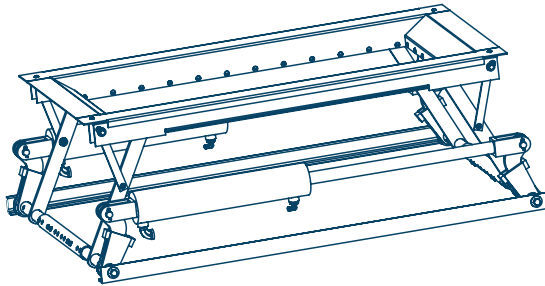

Part # Prefix & Model #: SBL-24 or SBL-30

Funnel Opening:

SBL-24: 22 x 42 in. (559 x 1067 mm)

SBL-30: 30 x 42 in. (762 x 1067 mm)

SBLR-18

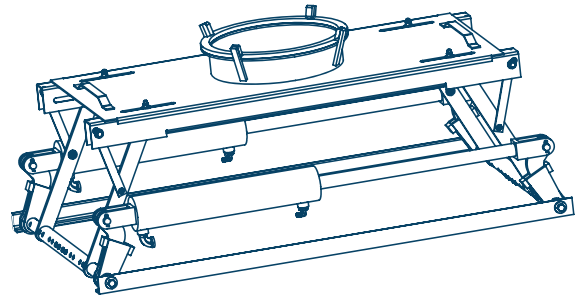

Part # Prefix & Model #: SBLR-18

Funnel Opening:

15 in. (381 mm)

DOUBLE-OPENING ASSEMBLIES FOR DOUBLE-GATE HOPPERS

DBL-18

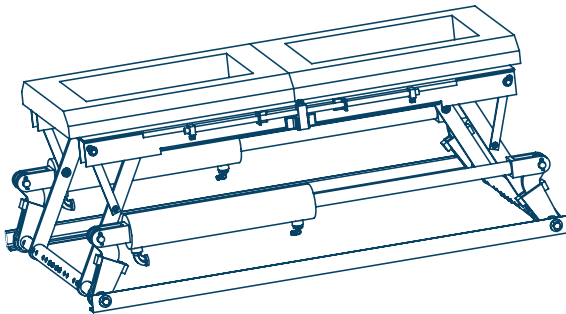

Part # Prefix & Model #: DBL-18

Funnel Openings:

12.5 x 16.5 in. (318 x 419 mm)

DBLG-18/GATX

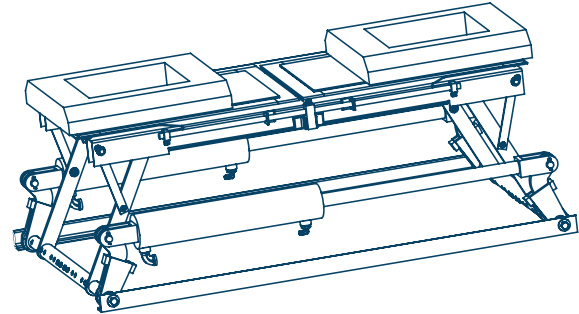

Part # Prefix & Model #: DBLG-18

Funnel Openings:

12.5 x 16.5 in. (318 x 419 mm)

Closed Width:
54 in. (1372 mm)

Opened Width:
69 in. (1753 mm)

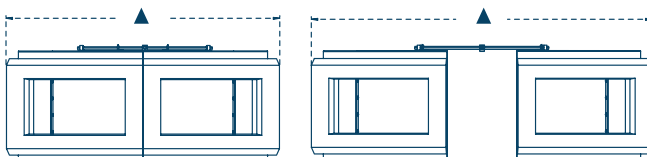

Closed Width:
55.4 in. (1407 mm)

Opened Width:
78.5 in. (1994 mm)

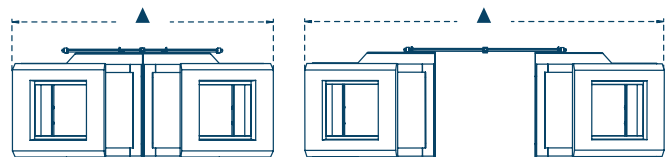

Build-a-Boot-Lift

Custom Part Number

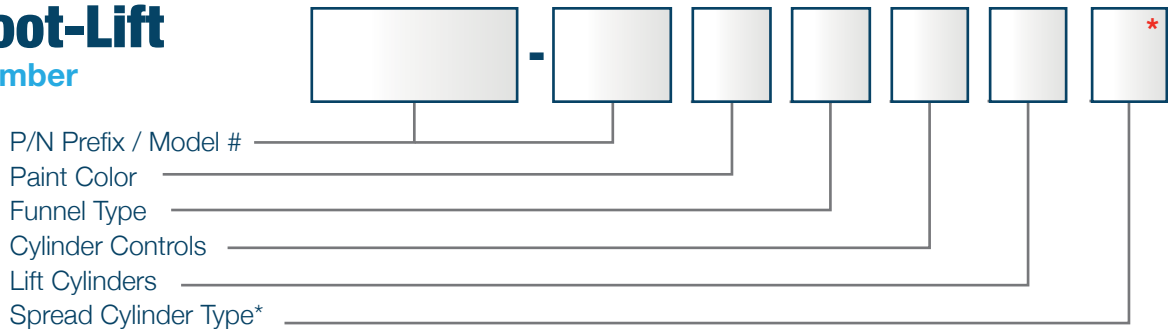

**Double-opening assemblies only.*

PAINT COLOR

S: Orange (Standard)
F: White (Food Grade)
C: Gray (Corrosion Resistant)

FUNNEL TYPE

Ø: No Funnel
1: Painted Funnel
2: Stainless Funnel

CONTROL CONSOLE

Ø: No Controls
1: Air-Over-Hydraulic Controls

LIFT CYLINDERS

Ø: No Lift Cylinders
1: Hydraulic Lift Cylinders

SPREAD CYLINDERS*

Ø: No Spread Cylinders
1: Standard Hardware
2: Stainless Hardware

EXAMPLE



INNER DIMENSIONS OF THE RECEIVING HOPPER OPENINGS:	
SINGLE OPENINGS	Length (A) _____ x Width (B) _____ Bottom of rail to top of hopper (F) _____
	Length (A) _____ x Width (B) _____ Distance between openings (C) _____ Bottom of rail to top of hopper (F)* _____

* 3-inch minimum required.

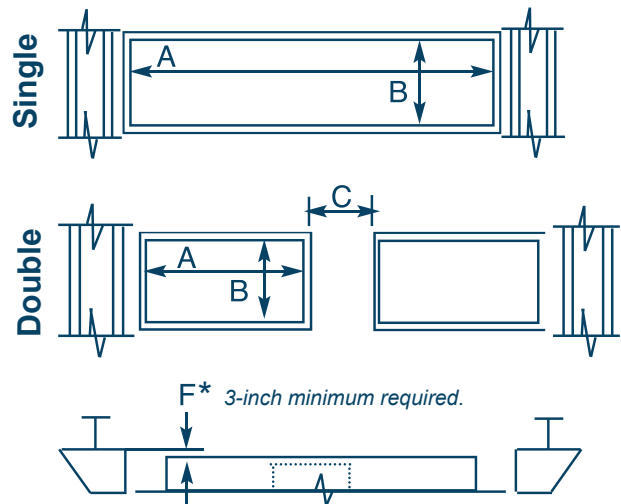

Build-a-Boot

Custom Part Number

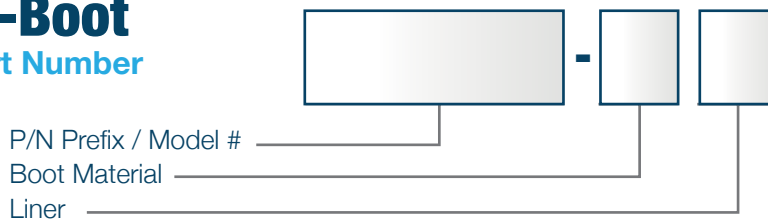

P/N PREFIX / MODEL

19760: SBL-24 21055: SBLR
35038: SBL-30 17840: DBL-18

BOOT MATERIAL

B: Black Vinyl F: Food Grade
H: White Hypalon R: Flame Retardant

LINER

L: 0.01 Polyethylene Liner
Ø: No Liner

SINGLE & DOUBLE-OPENING ADAPTER SHEETS (AS)

 **Sponge Seal**
(4-inch width)

SBL-24AS/-30AS

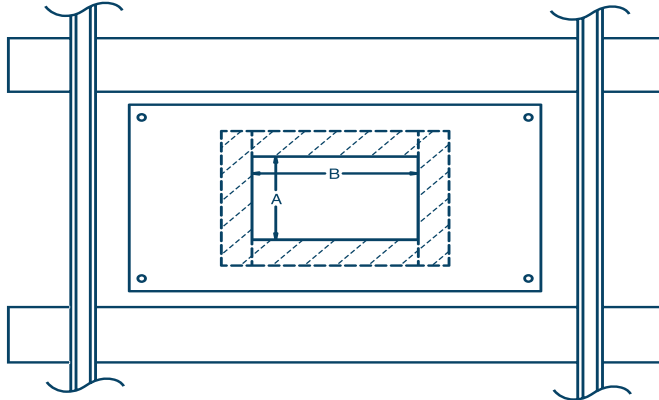

Part # Prefix & Model #:
SBL-24AS or SBL-30AS

DBL-18AS

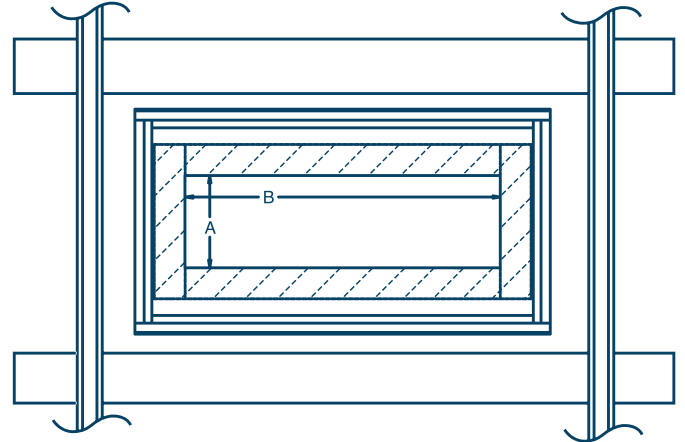

Part # Prefix & Model #:
DBL-18AS

*For use with a
transition funnel.*

TRANSITION FUNNELS

These convert various models from double to single-opening unloading. Simply remove the standard Sponge Seals and install the appropriate Transition Funnel and Adapter Sheet.

DBL Transition Funnel

P/N 17272

Converts DBL and DBLG to SBL; requires DBL Adapter Sheet to fit opening.

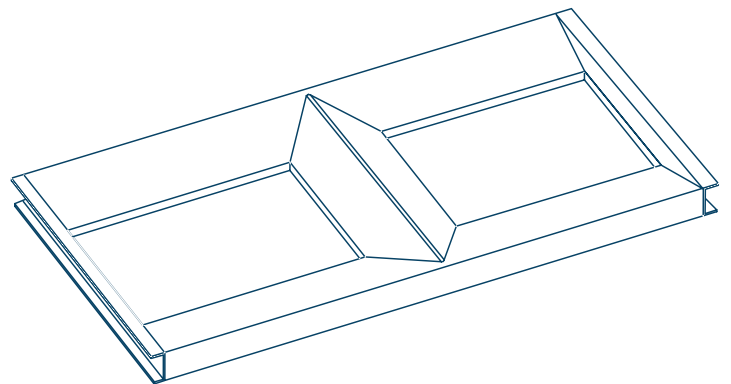

ADAPTER SHEET SIZES

Opening size examples. Approximate opening size in inches (A x B).*

SBL-24AS Sizes				in. (mm)	
Dim. A		Dim. B			
12	(305)	41	(1041)		
13	(330)	30	(762)		
13	(330)	48	(1219)		
16	(406)	42	(1067)		
17	(432)	24	(610)		
19	(483)	22	(559)		
19	(483)	24	(610)		
19	(483)	26	(660)		

SBL-30AS Sizes				in. (mm)	
Dim. A		Dim. B			
12	(305)	42	(1067)		
19	(483)	42	(1067)		
24	(610)	30	(762)		
24	(610)	42	(1067)		
30	(762)	24	(610)		
30	(762)	30	(762)		
32	(813)	36	(914)		
30	(762)	42	(1067)		

DBL-18AS Sizes				in. (mm)	
Dim. A		Dim. B			
12	(305)	23	(584)		
12	(305)	41	(1041)		
13	(330)	48	(1219)		
15	(381)	30	(762)		
16	(406)	24	(610)		
16	(406)	44	(1118)		
23	(584)	29	(737)		
24	(610)	42	(1067)		

* Gate opening can measure as listed dimension plus up to 4 additional inches (101 mm).
 Example: A 17 x 24 inch adapter sheet will fit a gate opening up to 21 x 28 inches.

▼ Refer to the sizing chart above and the part number key below.

P/N Prefix / Model # _____

Opening Size _____

Material Type _____

Foam Wrap _____

MATERIAL TYPE

W: Wood H: High-Density Polyethylene

FOAM WRAP

Ø: No Wrap W: White Vinyl (FDA Nitrile)

EXAMPLE: SBL - 30AS 1342 H W

Martin Railcar Openers power open stubborn car-bottom gates, reducing safety risks for personnel and improving unloading efficiency.

The weight of the railcar's cargo load against the discharge gate makes the gate very hard to open. Martin Railcar Openers use compressed air to provide powerful force to open even the most stubborn gate, improving the efficiency and safety of unloading operations.

MARTIN RAILCAR OPENER P/N 38475 | Tech Data Sheet L3534

The Martin Railcar Opener is a powerful solution to improve the efficiency of railcar unloading. It easily opens tough railcar hopper gates without backbreaking labor, gate damage or high noise.

Powerful: 2700 ft-lb (1225 kg-m) of torque at 90 psi (6.2 bar).

Maneuverable: Three pivoting wheels allow for maximum maneuverability; unit can easily be positioned by one worker.

Adjustable Height: Change capstan height to fit various car gates and compensate for variations in unloading platforms. Handle easily adjusts to suit operator preference.

Adjustable Width: Stabilizers slide out to provide wide base for increased leverage; slide in to fit through narrow doors and small spaces.

Durable: Steel tube frame provides long life in "real world" conditions. 10" x 4" pneumatic wheels maneuver easily over rough rail-side conditions.

Controlled & Efficient: Smooth, non-impacting force opens gate without damage or high noise (83 dBa at operator position). Operates from 90–120 psi (6.2 to 8.2 bar) air supply at 20 cfm (566 L/min).



MARTIN GATE JACK OPENER



P/N M90 | Tech Data Sheet L3595

This air-powered wrench provides up to 1750 ft-lb (235 kg-m) of torque to open the most stubborn rack and pinion hopper gate.

Fast, Efficient Unloading: Spot the car, open the gate and start unloading. There's no time wasted trying to muscle the gate open.

One-Worker Operation: Weighs only 45 lb (20 kg) for easy positioning and use by one worker.

Efficient Air Use: Operates from an air supply of 20 cfm (566 L/min) at 80 to 125 psi (5.5 to 8.6 bar).

Easy To Apply: Capstan extension reaches even "hard-to-get-at" recessed railcar capstans.

The vibration of a railcar over the track will compact the car's bulk material cargo, prohibiting the cargo from flowing out freely once the discharge gate is opened. Railcar Vibrators from Martin Engineering provide powerful vibratory energy that enhances material flow to achieve full unloading. Martin® Railcar Vibrators will help you receive the cargo you paid to have shipped to your facility.



IMPACTING RAILCAR VIBRATOR P/N 38857 | Tech Data Sheet L3832

Linear vibrator provides powerful force to boost material flow. Lightweight vibrator and shoe make mounting/dismounting a strain-free procedure.

Compact vibrator and mount assembly provides plenty of power to unload the most stubborn materials.

Vibrator and wedge system weighs only 48 lbs (21 kg), reducing risk of injury from manhandling large, cumbersome vibrators into railcar brackets.



4400 SERIES RAILCAR VIBRATOR P/N 893210 | Tech Data Sheet L3849

4-inch hardened pistons

Low air consumption

Produces uniform directional force

3-INCH IMPACTING RAILCAR VIBRATOR P/N AP5-300RC | Tech Data Sheet L4117

The Martin 3-inch Impacting Railcar Vibrator with integral wedge fits into hopper bracket to provide powerful forces to unload bulk materials from railway cars.

Three-inch impacting piston provides up to 1699 force pounds and 3200 vpm (Vibrations Per Minute) at 80 psi to promote and maintain material flow

Handle for ease of placement and removal



BRUTE[®] MOTOR DRIVEN RAILCAR VIBRATOR
Tech Data Sheets L3412 / L3413

A motor-driven eccentric provides powerful rotary force to improve railcar unloading efficiency.

Clamp foot provides for fast, simple mounting.

Rugged construction features ductile iron case with aluminum end bell. Sealed oilbath bearings eliminate the need for lubrication.

Pneumatic- or hydraulic-powered models provide up to 9600 force-pounds (42,725 N) at 80 psi (4.14 bar).



VIBROTOR[™] CCR VIBRATOR
P/N CCR-4400 | Tech Data Sheet L2581

This simple, long-lasting portable pneumatic vibrator provides effective high-frequency vibration. Apply to railcars, chutes, screens and compaction tables to prevent material buildup.

The simple, long-lasting Vibrotor[™] CCR Vibrator provides effective high-frequency vibration at an economical price.

Generates multiple vibrations on each orbit

Eliminates wear problems and extends service life



AIRMATIC founded in 1944, is a woman-owned Industrial Distributor, with installation and maintenance capabilities, offering equipment, machinery, and shop supplies to the Industrial, Construction, Utility, Government, and Commercial Markets. Our products and services are sold through three business units:

The **MATERIALS MANAGEMENT GROUP** provides products and services to industries that convey, store, transport, and process powders and bulk solids from aggregates, cement, and chemicals to foods, grains, metals, power generation, and waste water treatment applications;

The **SERVICE GROUP** provides fabrication, installation, and maintenance services to improve bulk materials handling efficiency; mechanical clean-out services for silos and hoppers to eliminate material flow problems; and shop repair/rebuilding and modifications services of products sold by the Company.

The **TOOL GROUP** provides power tools, personal protective equipment, materials-handling equipment, shop equipment and MRO supplies used for production, fabrication, assembly, metal removal, maintenance, and storage in manufacturing, construction, utility, and commercial applications.

Our Customers tell us that by choosing AIRMATIC to solve their problems, they gain increased productivity, decreased costs, and a safer, cleaner work environment.

The logo for MARTIN features the word "martin" in a bold, orange, italicized sans-serif font with a registered trademark symbol (®).

martin®

MARTIN ENGINEERING is the leading global supplier of system to make the handling of bulk materials cleaner, safer, and more productive. Since its founding in 1944, the company has grown dramatically through the development of solutions to help the solids-handling industries around the world. MARTIN ENGINEERING's success can be attributed to the development of practical, field-proven, cost-effective answers for "real life" problems. MARTIN Products are designed for tough industrial conditions; they are built to allow easy maintenance; they are engineered for simplicity, cleanliness, safety, and efficiency; they are personalized to meet each customer's unique requirements.

AIRMATIC

284 Three Tun Rd. Malvern, PA 19355

215.333.5600

infocenter@airmatic.com

airmatic.com