

AIRMATIC®
WE'LL HANDLE IT.



martin®

BELT CLEANERS

Carryback Removal Solutions

AIRMATIC

284 Three Tun Rd. Malvern, PA 19355

215.333.5600

infocenter@airmatic.com

airmatic.com

PROBLEM

CONSEQUENCES OF CARRYBACK

Carryback is material that sticks to the belt past the discharge point and then drops off along the conveyor's return run.

Without belt cleaners, material carryback causes...

- Reduced operating efficiency and profitability through increased expenses for maintenance, cleanup and the loss of material
- Material buildup on rolling components leading to seized idlers, wandering belts and increased power consumption
- Lower plant morale as employees sense the “I don't care if it's dirty” attitude
- Unsafe working conditions caused by material accumulation on floors and walkways, creating fire hazards and slip/trip hazards
- Health hazards and environmental concerns created by airborne material
- Unfavorable attention from neighbors and regulatory agencies



SOLVED!

CARRYBACK REMOVAL SOLUTION

Belt cleaner systems from Martin Engineering make conveyor systems cleaner, safer and more productive.

With belt cleaners, minimized carryback results in...

- Improved maintenance planning and conveyor availability as emergency outages, unscheduled downtime and “hurry-up” repairs are reduced
- Reduced maintenance expenses by lower labor costs for fewer and faster service procedures
- Improved manpower utilization by fewer belt-tracking and material-cleanup chores
- Maximized equipment life by fewer replacements of prematurely worn components damaged by fugitive material and buildup
- Improved working conditions, plant safety and morale by better housekeeping
- Improved community relations and regulatory compliance by reducing environmental pollution



MARTIN PRIMARY CLEANERS

As the first stage in a multiple cleaner system, the primary cleaner removes the majority of material adhered to the belt, leaving only a thin layer of sticky fines.

Primary cleaners are generally tensioned at low pressure—roughly 2 psi (13.8 kPa)—against the belt. Low blade-to-belt pressure allows the primary cleaner to be positioned at a peeling angle against the belt. The use of higher pressure at this angle would endanger the belt, splice or cleaner itself.

Primary cleaners are typically installed on the face of the head pulley, just below the material trajectory. The cleaner should be constructed to avoid material buildup and installed so that it is out of the material

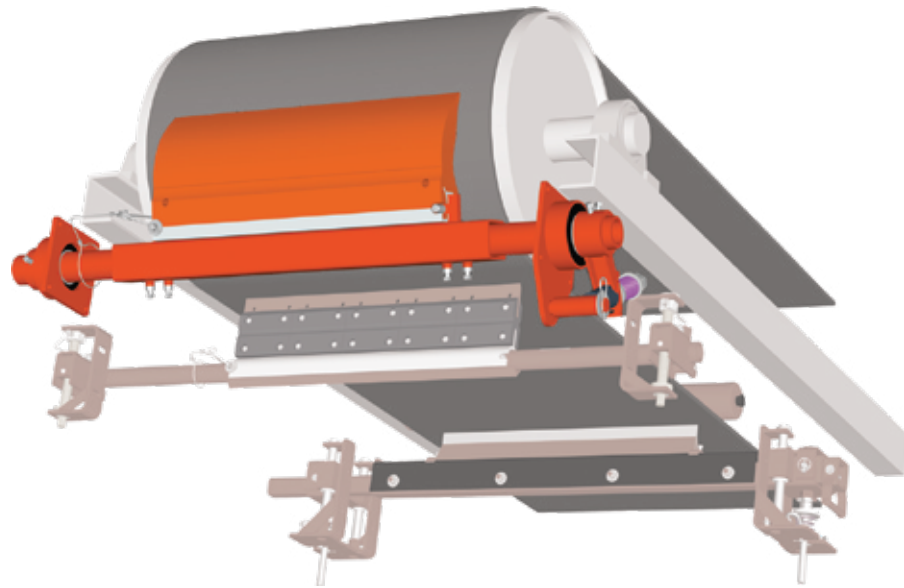

SELECTION GUIDE REQUIRED DATA

- Belt width
- Head pulley diameter
- Belt speed
- Material characteristics
- Application temperature

SELECTION PROCESS

1. Identify the specifications for your conveyor.
2. Use your conveyor's specifications for belt width and pulley diameter to select a primary cleaner in the Primary Cleaner Sizing Chart on the next page.
3. Check your selection against the recommended maximum belt speeds in the Primary Cleaner Scale Chart on the next page.
4. Use material characteristics and application temperature to identify the appropriate urethane blade in the chart on page 6.

Belt Width in. (mm)		Head Pulley Diameter—in. (mm)						
		7-10 (180-250)	12-16 (300-400)	18-22 (450-560)	24-30 (600-760)	32-38 (810-970)	40-46 (1010-1170)	48+ (1220+)
12	(300-400)	1	2	N/A	N/A	N/A	N/A	N/A
18	(400-500)	1	2	3 or 4	5 or 6	N/A	N/A	N/A
24	(500-650)	1	2	3 or 4	5 or 6	N/A	N/A	N/A
30	(650-800)	1	2	3 or 4	5 or 6	N/A	N/A	N/A
36	(800-1000)	1	2	3 or 4	5 or 6	N/A	N/A	N/A
42	(1000-1200)	N/A	2	3 or 4	5 or 6	7	N/A	N/A
48	(1200-1400)	N/A	2	3 or 4	5 or 6	7	7	8
54	(1400-1600)	N/A	2	3 or 4	5 or 6	7	7	8
60	(1600-1800)	N/A	2	3 or 4	5 or 6	7	7	8
72	(1800-2000)	N/A	2	3 or 4	5 or 6	7	7	8
84	(2000-2200)	N/A	3 or 4	3 or 4	5 or 6	7	7	8
96	(2200-2400)	N/A	3 or 4	3 or 4	5 or 6	7	7	8
108	(2600-2800)	N/A	N/A	N/A	N/A	7	7	8
120	(2800-3000)	N/A	N/A	N/A	N/A	7	7	8

1 = Compact Cleaner

2 = QB1™ PV Cleaner

3 = QC1™ Cleaner PD

4 = QB1™ Cleaner HD

5 = QC1™ Cleaner HD Max

6 = QC1™ Cleaner XHD

7 = SHD 600 Series Cleaner

8 = SHD 1200 Series Cleaner

Please note: Stainless steel mainframes and tensioners are available for corrosive environments. “Safe to Service” cleaners available for primary or secondary.

PRIMARY CLEANER SCALE & BELT SPEEDS

Maximum Belt Speed by Categories: fpm (m/sec)

Blade Dimensions given in inches (mm)

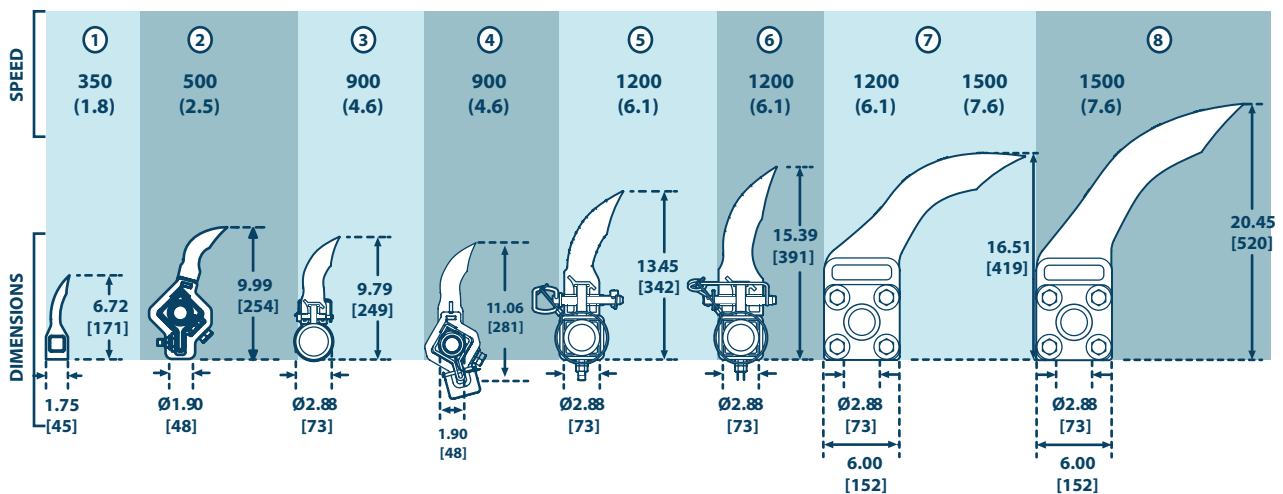

In instances of conflict between size and speed, choose the larger size.

PATENTED CARP CLEANER BLADES

Martin belt cleaner blades come in a large array of shapes, sizes and materials to most effectively remove any type of material carryback while protecting the belt and its splices.

Martin's patented Constant-Angle/Constant-Area Radial Pressure (CARP) blade design maintains consistent cleaning through all stages of blade wear.

HIGH-PERFORMANCE URETHANES®

Martin Engineering is the worldwide leader in the development of high-performance urethanes for specialized applications. Available for any Martin primary and secondary cleaners, as well as any primary cleaner supplied by another manufacturer.

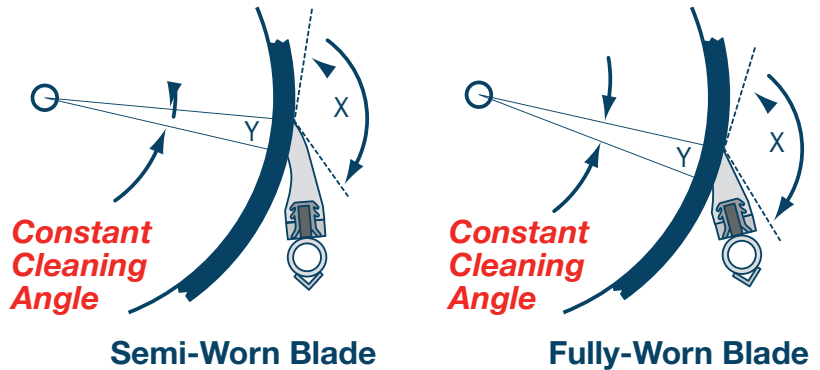

Martin CARP Blades are protected by U.S. Patent No. 4,917,231.

Color	Application Description	Typical Materials	Temp. Range
Orange (OR [or blank])	Standard Martin Urethane is suitable for most applications, including abrasive conditions and exposure to solvents or oil.	Bauxite, coke, coal, refuse, steel/ore, etc.	-20° to 160°F
Brown (BR)	Chemical-Resistant Urethane provides improved resistance to chemicals and reduced water absorption in high-moisture environments.	Limestone	-40° to 160°F
Green (GR)	High-Temperature Urethane withstands exposure to intermittent temperatures of up to 350°F.	Clinker	-40° to 300°F
Tan (CL)	Low-Rigidity Urethane is ideal for dry products such as sand and gravel.	Gravel, dry sand	-20° to 160°F
Navy Blue (NB)	Low-Adhesion Urethane is ideal for sticky or tacky materials.	Cement, glass, wood chips	-20° to 160°F
Yellow (CY)	Ceramic Bead is ideal for aggressive applications	Cement, glass, wood chips	-40° to 160°F

MARTIN QC BLADE REPLACEMENT

One-pin blade replacement makes belt cleaner blade replacement an easy, one-minute, no-tool operation performed from outside of the chute. Simply (1) remove the R-clip and (2) slide the hitch pin out of the mainframe extrusion to (3) release the blade.



1. Remove the R-clip.

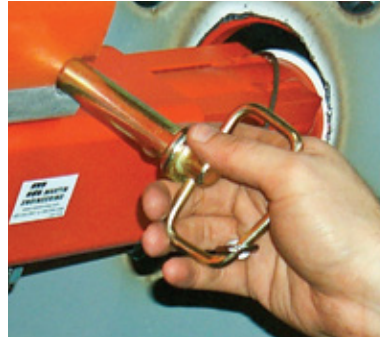

2. Slide the hitch pin out.



3. Release the blade.

MARTIN QC1 BLADE OPTIONS

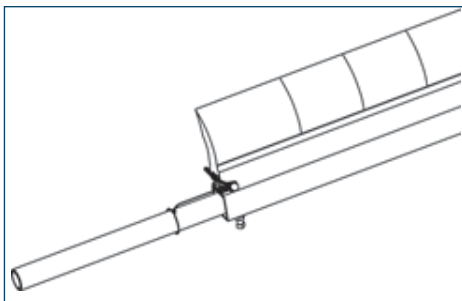

Segments only
XX10
(for crowned head pulleys)

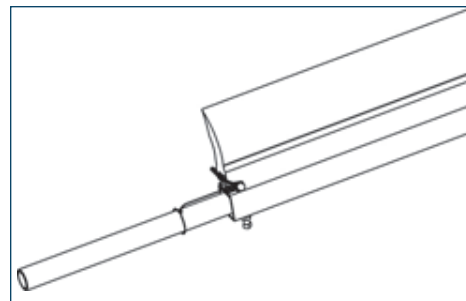

No segments
XX11

CLEANSRAPE® CLEANER

The CleanScape Cleaner lasts up to four times as long as traditional belt cleaners. Safe for use on mechanical and vulcanized splices, this metal-tipped cleaner provides aggressive cleaning without compromising

your belt. Requiring minimal ongoing maintenance, CleanScape needs only one tensioner adjustment—EVER. Installed at an angle, very little space for installation is required.



SPECIFICATIONS

Cleaner Type	Pulley Diameter in. (mm)		Belt Width in. (mm)	Maximum Belt Speed fpm (m/sec)	
	Min.	Max.		Vulcanized Splice	Mechanical Splice
CSP-S	12 (300)	20 (508)	18–48 (457–1219)	1100 (6)	800 (4)
CSP-M	22 (550)	34 (864)	18–72 (457–1829)	1500 (8)	800 (4)
CSP-L	36 (900)	50 (1270)	36–96 (914–2438)	1500 (8)	800 (4)

CARBIDE BLADE SELECTION

Carbide Selection	Application Description	Typical Materials
TU01	Suitable for less abrasive materials and low belt speeds. Applicable with mechanical belt splices.	Limestone, Salt, Sugar, Coal
TU02	Suitable for moderately abrasive materials and medium belt speeds. Applicable with mechanical belt splices.	Gravel, Clinker, Sandstone
TU03	Suitable for highly abrasive materials and high belt speeds. Do not use with mechanical belt splices.	Sand, Glass, Ore
TU04	Suitable for extremely abrasive materials and highest belt speeds. Do not use with mechanical belt splices.	Quartz Sand, Glass Ash, Ore
TU05	Suitable for conditions similar to TU01 and TU02 with chemical resistance. Applicable with mechanical belt splices.	

MARTIN COMPACT CLEANER

Fits in spaces with as little as 6.75 inches of clearance on pulleys as small as 7 inches in diameter.

Blades are available in high-performance urethane colors to match application requirements.

Patented “CARP” blade design maintains cleaning performance through all stages of blade life. To replace worn blade, slide new blade onto square tube mainframe. Supplied with internal spring tensioner.



CARP Blade

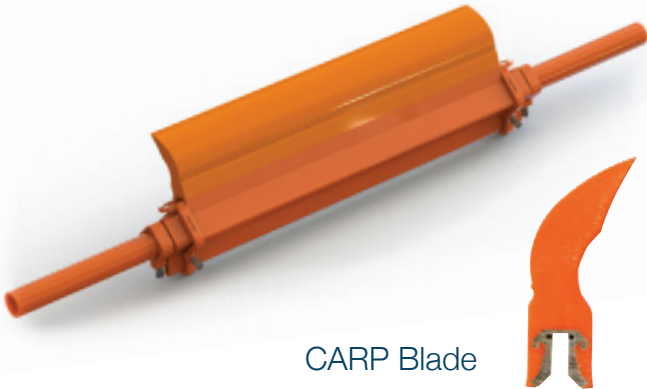

CARP Blade



MARTIN PV QB1 CLEANER ⚡

Same ease of installation as the current Martin QC1 Cleaners, maintaining standard installation and service costs.

Utilizes Martin’s highly effective patented “CARP” profile, ensuring the highest level of performance.

Utilizes Martin’s innovative EVO® design principles to reduce component surface exposure to material flow, minimizing material build-up and the resulting clean-up costs, production interruptions and safety concerns.

MARTIN QC1+™ CLEANER P⚡

Sturdy mainframe—2.875 in OD Schedule 80 steel pipe stands up to rugged conditions, large pulleys and heavy material loads.

The high-volume “CARP” blade features 20 percent more urethane than competitive cleaners. Durable and rugged spring tensioner maintains cleaning pressure, yet allows easy re-tensioning with minimal downtime.

Saves money at purchase by reducing the need for maintenance and blade replacements.

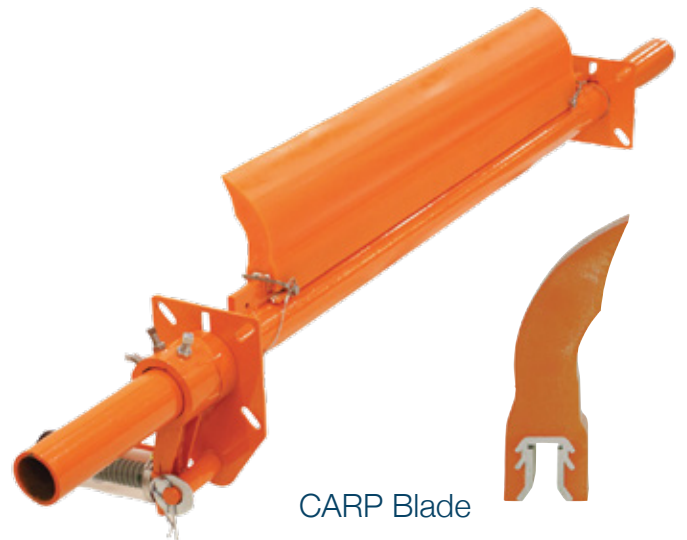

CARP Blade



⚡ Product can be powered by Martin Roll Gen System

MARTIN QB1™ CLEANER HD ⚡

Same ease of installation as current Martin QC1 Cleaners, maintaining standard installation and service costs. Utilizes Martin's highly effective, patented "CARP" profile, ensuring the highest level of cleaning performance expected from a Martin Belt Cleaner.

Utilizes Martin's innovative EVO® design principles to reduce component surface exposure to material flow, minimizing material build-up and the resulting clean-up costs, production interruptions and safety concerns.

- Direct retrofit to current installations; no need for new holes or cutting head chutes
- Direct retrofit to other manufacturer's frames
- Aluminum, steel or stainless steel component options available



QB1 HD Shown With Twist™ Tensioner

CARP Blade

MARTIN QC1™ CLEANER HD MAX ⚡

Unique blade profile means the blade maintains the most efficient cleaning angle across the extended wear life.

Mainframe of rugged 3/8-in. thick DOM steel tubing has steel bar backbone. Aluminum extrusion in blade base holds cleaner snugly to backbone.

Durable and rugged Martin Spring Tensioner XHD maintains cleaning pressure.

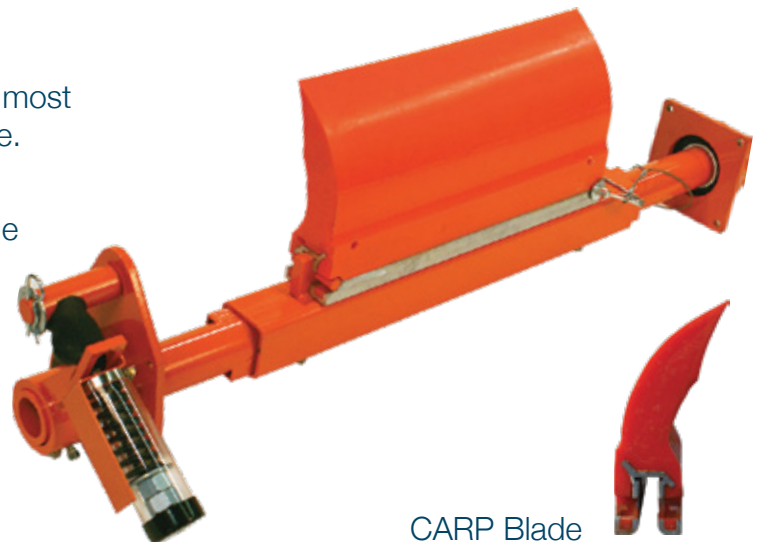

CARP Blade

⚡ Product can be powered by Martin Roll Gen System

CARP Blade



Also Available with Air Tensioner

MARTIN QC1+™ CLEANER HD & XHD STS

Designed to allow for all service to take place safely outside of the chute, eliminating the need for confined space permit while preventing injuries and keeping workers from harm's way.

The one-pin blade replacement makes service fast and easy. Patented "CARP" design maintains cleaning performance through all stages of blade life.

Economical cleaner and tensioner system combines effective cleaning, durable life and low-maintenance requirements. Available with either a Martin Spring Tensioner HD STS or a Martin Air Tensioner HD STS to maintain proper cleaning pressure while minimizing the need for adjustment.

MARTIN QC1+™ CLEANER XHD

Engineered to preserve the cleaning edge from high belt speeds and multiple splices.

Patented "CARP" blade design maintains cleaning performance through all stages of blade life. Mainframe of rugged 3/8-in. DOM steel tubing has a steel bar backbone.

An aluminum extrusion in the belt cleaner blade base holds the cleaner snugly to the backbone.



CARP Blade

MARTIN SHD 600 & 1200 SERIES CLEANERS

Structural steel means no more bent mainframes, even with high tonnages and large lumps.

Massive urethane blades provide up to 12 inches of wear life.

Martin SHD Cleaner and tensioner are designed together for effective cleaning and reduced service requirements.

Patented "CARP" blade design maintains cleaning performance through all stages of blade life.



CARP Blade

⚡ Product can be powered by Martin Roll Gen System

MARTIN SECONDARY CLEANERS

Installed at the point where the belt is leaving the discharge pulley, secondary cleaners remove residual fines that remain on the belt past the primary cleaner. Its location is typically close enough to the material trajectory that the cleanings will return to the main material stream.

Tertiary cleaners can be installed to provide final cleaning. These cleaners can be the same model as the secondary cleaner, or of a different design to allow efficient cleaning and maintenance within the available space.

As these cleaners are typically installed away from the pulley, they should be placed at or near a point where the belt is against a roller. Firm support prevents the cleaning pressure from raising the belt line and reducing cleaning efficiency.

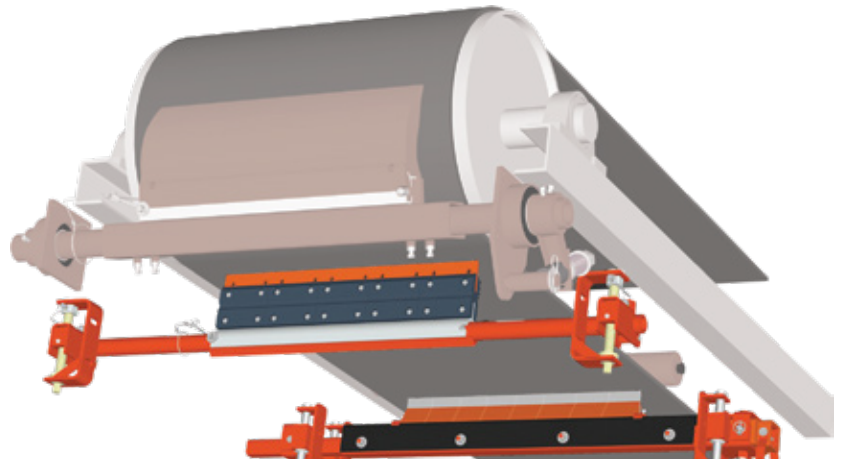

SELECTION GUIDE

1. Check your conveyor's belt speed against the specifications listed for the secondary cleaners in the table below.
2. If your belt features multiple mechanical splices, or a mechanical splice in poor condition, avoid using tungsten carbide blades as rapid wear or damage to both the blade and splice may result.

APPLICATION SPECIFICATIONS

Belt Cleaner	Max Belt Speed fpm (m/sec)	Handles Reversing Belts & Rollback	Available Blade Materials				
			Mild Steel	Stainless Steel	Tungsten Carbide	Urethane	SS / TC stainless steel holder with tungsten carbide inserts
DT2S Reversing Cleaner	900 (3.5)	X	X	X	X	X	X
SQC2S™ Cleaner	1000 (5.1)	X	X	X	X	X	X
SQC2 RM™ Cleaner	800 (5.1)	X			X		X
SQC2S™ Cleaner STS	1000 (5.1)	X	X	X	X	X	X
DT2H Inline Cleaner XHD	1200 (6.1)	X			X	X	X

Please note: Stainless steel mainframes and tensioners are available for corrosive environments.

MARTIN DT2S REVERSING CLEANER ⚡

Slide-in/slide-out belt cleaner blade cartridge allows quick and easy blade service that minimizes conveyor downtime. Even when the cleaner is encrusted with material, one-half of the split frame can be removed to allow blade change.

Effective belt cleaning reduces plant cleanup chores and prolongs life of conveying equipment.

Can be installed on conveyors that roll back or run in two directions with proper blade selection.

Lean profile minimizes space requirements, allows installation in spaces as narrow as seven inches.

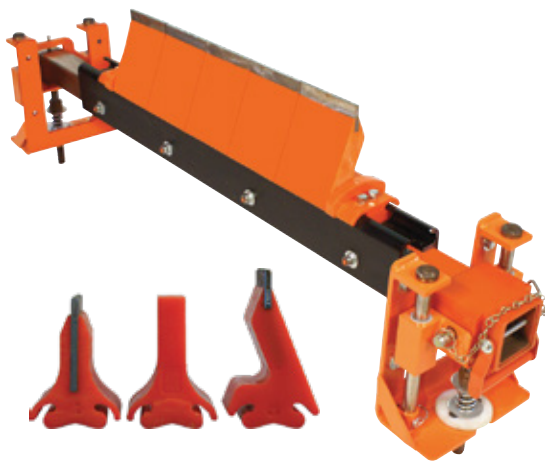
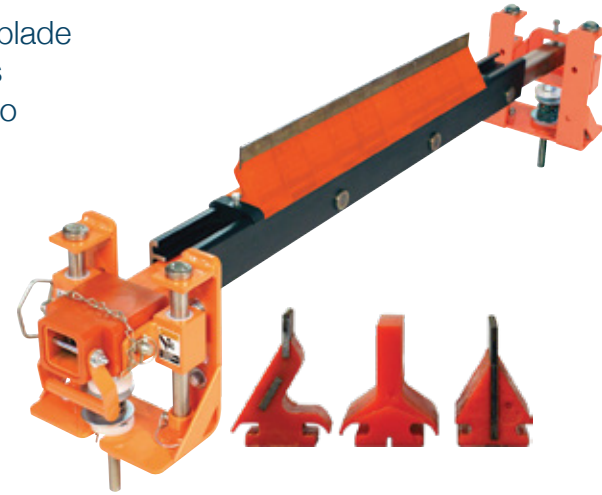

MARTIN DT2H REVERSING CLEANER XHD ⚡

Reduces plant cleanup chores and prolongs the life of conveyor components. Mandrel allows quick-and-easy belt cleaner blade replacement to increase conveyor availability.

Individual belt cleaner blade segments slide into sturdy track-forming cartridge. This cartridge slides over stainless steel mainframe into cleaning position.

The split-track cartridge design allows simple belt cleaner blade removal even with material accumulation.

MARTIN SQC2S™ CLEANER

Rugged construction withstands harsh applications like high-speed belts and high-tonnage loads.

Compact design allows installation in close quarters; narrow profile resists material buildup. Blade replacement is simple: remove the pin, slide the cartridge out, service and return.

SQC2S™ Cleaner cartridge comes with different blade options to suit your application.



SQC2S™ Blade with rubber buffers

⚡ Product can be powered by Martin Roll Gen System

MARTIN SQC2™ RM BLADES

Rugged construction withstands harsh applications like high-speed belts and high-tonnage loads. Reduced height resists material buildup. Blade replacement is simple: remove the pin, slide the cartridge out, service and return.

SQC2™ RM Cleaner cartridge comes with different blade options to suit your application.

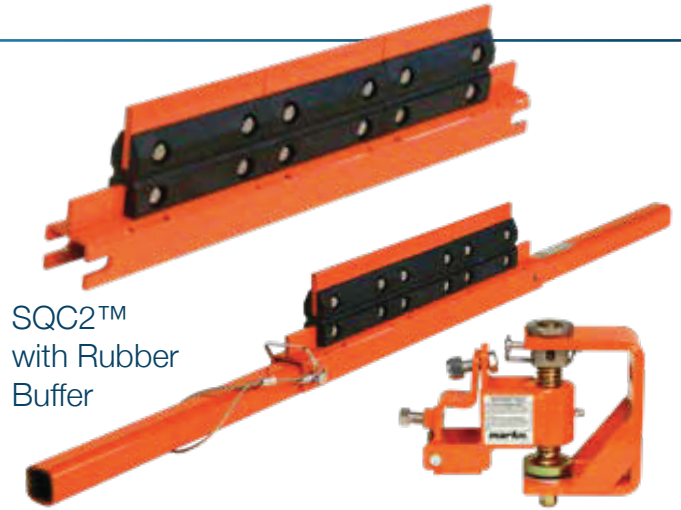

SQC2™
with Rubber
Buffer

RUBBER BUFFER

Patented rubber buffers maintain cleaning pressure while deflecting to allow for splices to pass and for reversal of belt direction without damage.

SAF BLADES

Light “touch” of resilient three-inch wide (75 mm) urethane blades reduces risk of damage, even on belts with multiple fasteners, rips or longitudinal splices or rollback. As cleaning edge wears, the urethane blades self-adjust to maintain effective cleaning.

Cartridge mounting provides easy removal of blades from mainframe. Pry out worn blades with a screwdriver and snap new blades into place.



SQC2S™
with SAF Blades

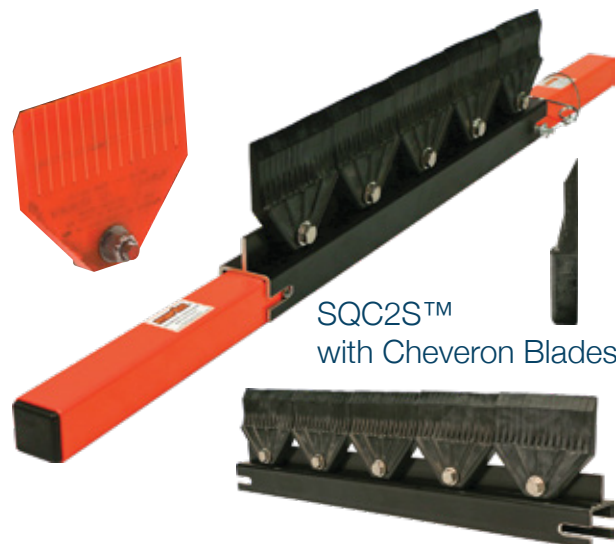

SQC2S™
with Chevron Blades

CHEVRON BLADES

Rubber or urethane chevron blades effectively remove carryback while gently stepping over ribs, chevrons, and cleats.

SQC2S™ CLEANER STS

Designed for safety, this cleaner helps prevent injuries and keep workers from harm's way during service. This safe-to-service cleaner allows for all service to take place from one side of the conveyor, avoiding the need for confined space entry. Blade replacement and maintenance is quick and easy:

- Disengage tensioner
- Pull blade cartridge outside of the conveyor
- Remove quick release pin & blade cartridge
- Replace blade
- Push cartridge back into position
- Engage the tensioner



MARTIN H2O CLEANER

Martin H2O Cleaner squeegees the belt to remove dirt and moisture. Suited for medium-duty applications, on 18- to 96-inch belts operating at speeds up to 750 fpm (3.8 m/sec).

Comes with the option of a spray nozzle to apply water to the belt to further improve cleaning efficiency.

Tensioners also available.

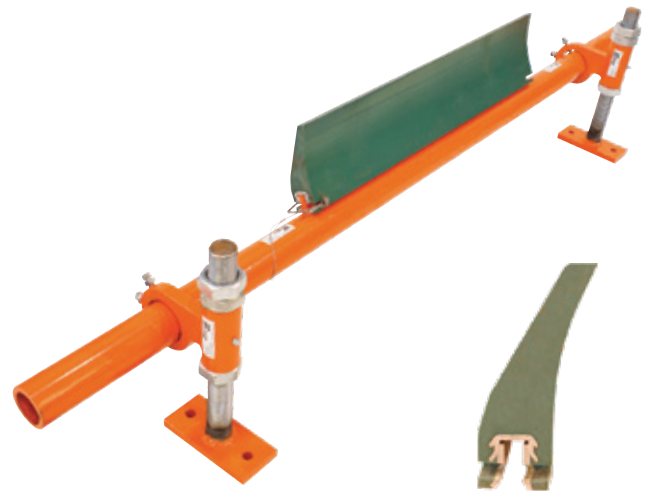

Compatible with DH2, SQC2, QC2, SAF, H2O and Reversing Cleaners.

PRESSURE ROLLER & BRACKETS

The Martin Pressure Roller Bracket stabilizes the conveyor belt, providing proper pressure for multiple conveyor belt scraper installations or where space limitations prevent installation on head pulley.



Universal
37954

SQC2S
or **QC2**
34542



DH2
32290



MARTIN FOOD GRADE CLEANER

Mounts on the face of the head pulley to reclaim material into the product stream.

Engineered to fit the conveyor specifications and belt cleaning requirements of the food processing and packaging industries.

Modular belt cleaner blades on stainless steel mainframes. Supplied with internal spring tensioner.



MARTIN BRUSH CLEANER

One or two-horsepower motor (depending on belt width) turns brush against belt motion. Spiral Brush Cleaner uses 0.38 inch polypropylene bristles wrapped in a spiral around the hub.

Strip Brush Cleaner uses 12 brush strips that sheds even moist material that would plug other brushes. Strips are made with 0.40 inch polypropylene bristles.

MARTIN HIGH TEMPERATURE CLEANER

All-steel construction allows the Martin High Temperature Cleaner to withstand high temperatures up to 600°F.

Overlapping stainless steel or tungsten carbide blades on coil spring arms provide effective cleaning.

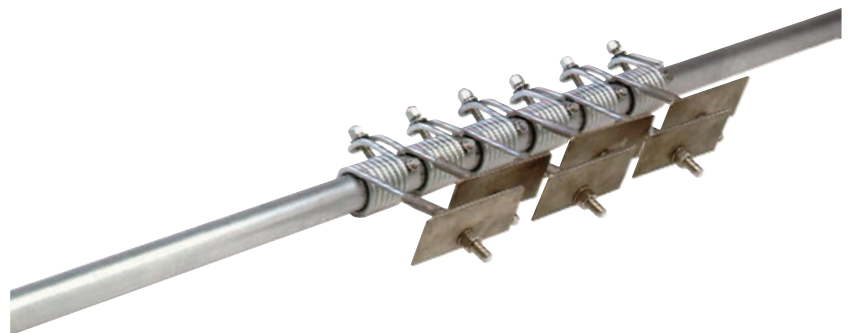



MARTIN CHEVRON CLEANER

Incorporates arms with blades offset at a 30° angle to allow the edge to ripple over belt cleats.

Use the Chevron Cleaner where stringy material like vines, wire or bark can catch on conventional cleaner arms.

Suited for V-pattern or U-pattern chevrons.

MARTIN WASHBOX™ CLEANING SYSTEM ⚡

Consists of a powder-coated steel enclosure equipped with 3 rollers, 4 spray bars, 4 inspection doors and 2 secondary cleaners.

Rather than “blast” material from the belt, the water softens the carryback.

The installation of a primary cleaner on the face of the head pulley is recommended.



A modular unit is shown with a standard box with two cleaners and a single cleaner box.

MARTIN CARRYBACK CAPTURE SYSTEM

Allows for the addition of secondary and tertiary cleaners outside the head chute and returns removed carryback to the cargo stream.

Reduce worker risks and cleanup costs by moving carryback away from moving parts and confined spaces.

Modular construction increases portability and makes installation easy in any unique or confined spaces; system requires only 13 inches of clearance for easy installation in tight spaces.

Minimal moving parts increase reliability and minimize opportunities for breakdowns.



⚡ Product can be powered by Martin Roll Gen System



MARTIN TWIST™ TENSIONER

The Martin Twist Tensioner can be used on either primary cleaners or secondary cleaners.

Rubber element maintains cleaning pressure with minimal belt cleaner re-tensioning required.

Tensioner allows mechanical splices to pass without damage. If blades pull through, the tensioner's coupling rolls over, releasing pressure and reducing the risk of harm to personnel or equipment. Light aluminum housing and the fully enclosed design keeps the tensioner mechanism clean.

MARTIN SPRING & AIR TENSIONERS

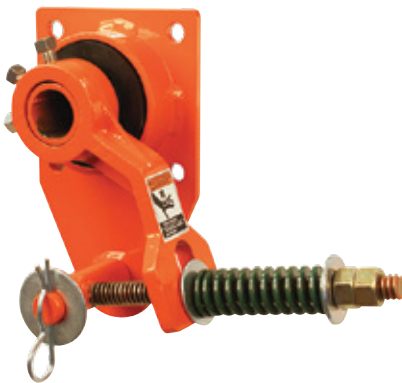

MARTIN SPRING TENSIONERS

maintain efficient belt cleaning with a rugged coil spring.



MARTIN SPRING TENSIONER XHD

Provides effective cleaning pressure, yet cushions splice shock to prevent damage. Provides effective tension for heavy-duty belt cleaners and stands up to tough conditions.

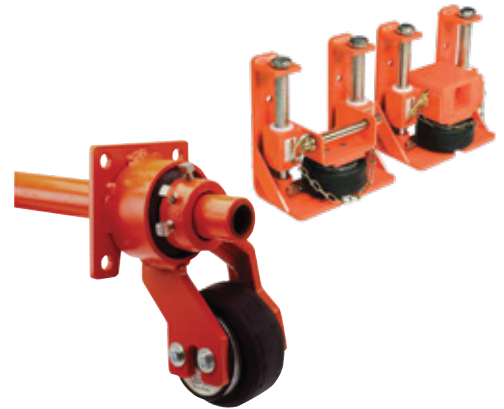

MARTIN AIR TENSIONERS

use the resilience of an air spring to cushion impact.



Air Tensioner Control Panel

Air Cylinder

AIR TENSIONER CONTROL BOX

Safe and effective regulating of air pressure to air tensioning systems. Unit maintains the proper blade-to-belt cleaning pressure for primary and secondary belt cleaners.

Effective control of single-acting cylinders or airbag belt cleaner tensioning systems.

MARTIN ROLL GEN™ SYSTEM

Self-contained, mini 24-Volt DC power station that generates enough power to run a wide variety of electronic systems:

- Compressor for Air Tensioner
- Activation of Water Supply to Wash Box Belt Cleaning System
- Initiation of Spray Bars
- Firing of an Air Cannon
- LED Lighting

Reversing Tracker Switching Mechanism Martin Roll Gen System* consists of:

Martin Roll Generator (3-year warranty) coupled with either:

- Martin Roll Gen Power Supply
- Martin Roll Gen Continuous Power Supply



*Mounted on Trac-Mount™ Idler Frame. Depending on your existing setup,

MARTIN VIBRATING DRIBBLE CHUTE

Keep material accumulations from clogging chute and burying cleaners.

Low-friction plastic lining promotes material flow without accumulation.

Rubber-lined bracket transfers vibration to liner without metal fatigue.

Electric vibrator provides durable performance.

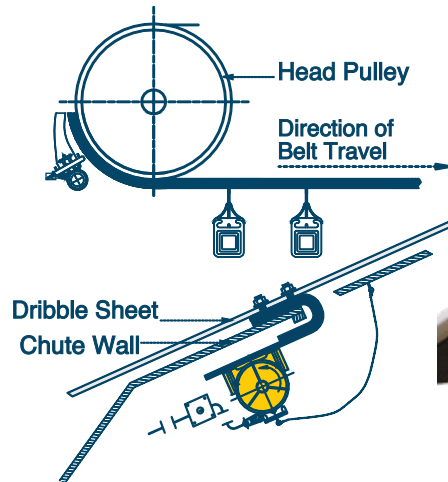

Vibrating dribble chute



MARTIN INSPECTION DOOR

Latch handle folds down, so door stands only 2.25 inches high. With handle standing, door is 4.1 inches high.

Suitable for service temperatures up to 400° F continuous or 450° F intermittent.

Also available with integral guard screen.



Martin offers replacement blades for all Martin belt cleaners as well as systems from any manufacturer.

FEATURES AND BENEFITS

- Effectively eliminate material carryback
- Reduce lost material
- Decrease maintenance hours and expenses
- Fewer blade changes means less downtime
- Best price per performance of ANY blade on the market
- All Martin Primary Blades utilize our patented CARP

“Containing 20% more urethane in the wearable area than competitive blades Martin blades clean better and last longer!”

(Constant Angle Radial Pressure) profile, ensuring consistent cleaning across all stages of blade life.

Martin
QC1™ Cleaner HD
Replacement Blade

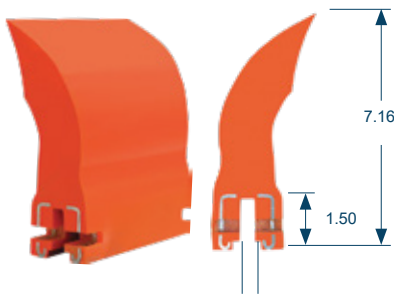

Martin
PV Cleaner
Replacement Blade

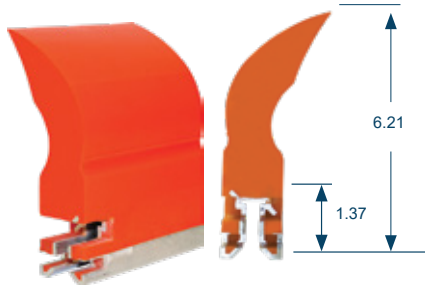

Martin
QB1™ Cleaner HD
Replacement Blade

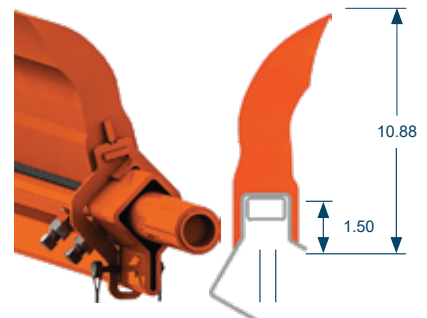

Martin
PV QB1 Cleaner
Replacement Blade

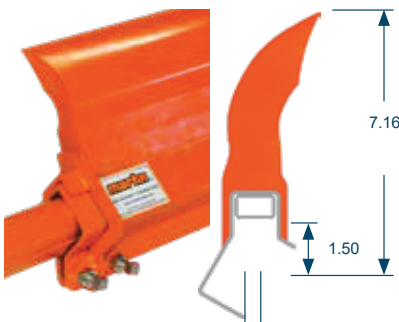

20% MORE URETHANE!

American Eagle[®] E4 Series
Primary Cleaner

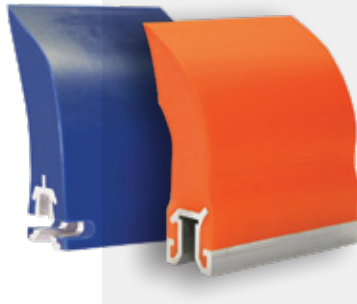

American Eagle[®] E5 Series
Primary Cleaner

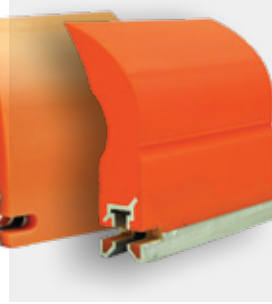

ASGCO[®] Skalper[®]
Primary Cleaner



Flexco[®] EZP1 Rockline[®]
Primary Cleaner



Flexco[®] MMP
Primary Cleaner



Argonics[™] Eraser
Primary Cleaner



BENETECH[®] BEP1
Primary Cleaner

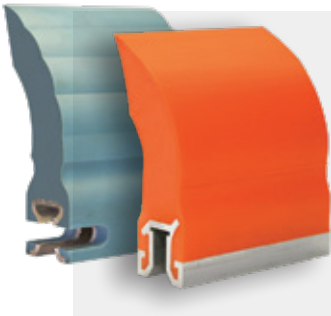

ARCH Saber[®] (SB)
Primary Cleaner

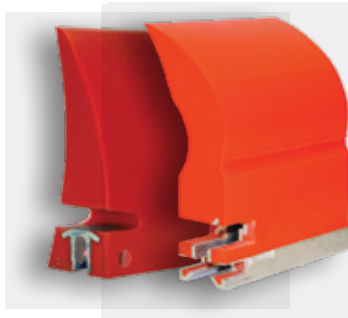

ARCH Saber[®] (SCM)
Primary Cleaner



SUPERIOR Exterra[®]
Primary Cleaner

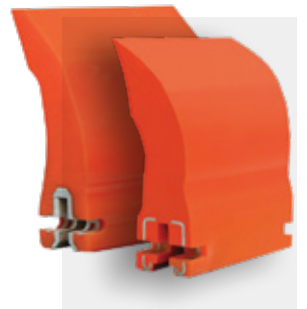

MARTIN® CLEANSRAPE® CLEANER

Assembly P/N	CSP-X
Carbide Selection	TU0X
Technical Data Sheet P/N	L4040
Maximum Belt Speed	1500 fpm
Belt Width	18-96 in.
Pulley Diameter	12-50 in.

MARTIN® QB1™ CLEANER HD

Assembly P/N	39346
Blade P/N	39344
Technical Data Sheet P/N	L4021
Maximum Belt Speed	900 fpm
Maximum Belt Width	96 in.
Pulley Diameter	16-22 in.

MARTIN® QC1™ CLEANER PD

Assembly P/N	38556
Blade P/N	35381
Technical Data Sheet P/N	L3799
Maximum Belt Speed	900 fpm
Maximum Belt Width	84 in.
Pulley Diameter	16-22 in.

SECONDARY CLEANERS
MARTIN® DT2S REVERSING CLEANER

Assembly P/N	DT2S
Reversing Blade P/N	31104
Cartridge P/N	DT2SC
Spring Tensioner P/N	37707
Air Tensioner P/N	37707-A
Technical Data Sheet P/N	L3685
Maximum Belt Speed	1000 fpm
Belt Width	24-96 in.

MARTIN® SQC2 RM CLEANER

Assembly P/N	SQC2RM
Technical Data Sheet P/N	L4093
Blade P/N	SQC2RMC
Maximum Belt Speed	800
Belt Width	18-72 in.

MARTIN® QC1™ CLEANER HD MAX

Assembly P/N	38926
Blade P/N	38900
Technical Data Sheet P/N	L3885
Maximum Belt Speed	1200 fpm
Maximum Belt Width	72 in.
Pulley Diameter	24-30 in.

MARTIN® QC1™ CLEANER XHD

Assembly P/N	35899
Blade P/N	35897
Technical Data Sheet P/N	L3799
Maximum Belt Speed	1200 fpm
Maximum Belt Width	120 in.
Pulley Diameter	24-30 in.

MARTIN® QC1™ CLEANER XHD STS

Assembly P/N	STSXHDQC
STS Tensioner	39100
Technical Data Sheet P/N	L3997
Maximum Belt Speed	1200 fpm
Belt Width	24-72 in.
Pulley Diameter	24-30 in.

MARTIN® DT2H REVERSING CLEANER XHD

Assembly P/N	DT2H
Reversing Blade P/N	32494
Cartridge P/N	DT2HC
Spring Tensioner P/N	37806
Air Tensioner P/N	37806-A
Technical Data Sheet P/N	L3690
Maximum Belt Speed	1200 fpm
Belt Width	18-96 in.

MARTIN® SQC2S™ CLEANER STS

Assembly P/N	STSSQC2S
SQC2S™ Blade Cartridge	SQC2SC
Maximum Belt Speed	1000 fpm
Belt Width	18-96 in.
Far-Side Tension Adjuster	38664-DXX
HD Hanger Mount Assembly	34233-HD

MARTIN® COMPACT CLEANER

Assembly P/N	33464
Blade P/N	33463
Technical Data Sheet P/N	L3667
Maximum Belt Speed	350 fpm
Maximum Belt Width	48 in.
Pulley Diameter	6-10 in.

MARTIN® PV QB1 CLEANER

Assembly P/N	39424
Blade P/N	39423
Technical Data Sheet P/N	L4084
Maximum Belt Speed	500 fpm
Maximum Belt Width	72 in.
Pulley Diameter	10-16 in.

MARTIN® SHD 600 & 1200 SERIES CLEANERS

Assembly P/N	SH1X
600 Series Blade P/N	35568
1200 Series Blade P/N	35569
SHD Turnbuckle Tensioner	35600
SHD Spring-Link Tensioner	35978
Technical Data Sheet P/N	L3439
Maximum Belt Speed	1500 fpm
Maximum Belt Width	120 in.
600 Series Pulley Dia.	30-48 in.
1200 Series Pulley Dia.	48+ in.

MARTIN® SQC2S™ CLEANER

Assembly P/N	SQC2S
SQC2S™ Blade P/N	SC-10002
SAF-2™ Blade P/N	38231
Rubber Buffer	SC10001MR
Cartridge P/N	SQC2SC
Technical Data Sheet P/N	L3686
Maximum Belt Speed	1000 fpm
Belt Width	18-96 in.
Sq. Mainframe Tensioner	3664
Sq. Mainframe Tensioner HD	38664-HD
Far-Side Tension Adjuster	38664-DXX

MARTIN® H2O CLEANER

Assembly P/N	H2O4000S
Technical Data Sheet P/N	L3831
Blade P/N	H2O4001
Maximum Belt Speed	—
Belt Width	18-84 in.

MARTIN[®] FOOD GRADE CLEANER

Primary Assembly P/N	33035
Internal Spring Tensioner P/N	33036
Secondary Assembly P/N	31369
Food Grade Air Tensioner P/N	31348
Food Grade Hub Mount Tensioner P/N	31368
Technical Data Sheet P/N	L3370-08
Maximum Belt Speed	350 fpm
Belt Width	4-48 in.

MARTIN[®] BRUSH CLEANER

Strip Assembly P/N	35331
Spiral Brush Assembly P/N	32875
Spiral Polypropylene Brush P/N	28898
Spiral Nylon Brush P/N	28560
Strip Brush with Hubs P/N	35327
Brush Strips (Set of 12) P/N	35329
Technical Data Sheet P/N	L3431
Maximum Belt Speed	—
Belt Width	18-72 in.

MARTIN[®] HIGH TEMPERATURE CLEANER

Assembly P/N	21042
Tungsten Carbide Blade P/N	27924
Stainless Steel Blade P/N	16960
Technical Data Sheet P/N	L3370-12
Maximum Belt Speed	750 fpm
Belt Width	18-96 in.
Maximum Service Temperature	600° F

MARTIN[®] CHEVRON CLEANER

Torsion Arm Assembly P/N	36881
Inline Assembly P/N	33705
Technical Data Sheet P/N	L3370-11
Maximum Belt Speed	500 fpm
Belt Width	18-96 in.

MARTIN[®] WASHBOX CLEANING SYSTEM

Dual Belt Cleaner Assembly P/N	WBPXX
Single Belt Cleaner Assembly P/N	WBSCPXX
Technical Data Sheet P/N	L3780
Maximum Belt Speed	750 fpm
Belt Width	18-84 in.

TENSIONERS

MARTIN[®] TWIST™ TENSIONER

Single Tensioner P/N	38850-0X
Dual Tensioner P/N	38850-2X
Technical Data Sheet P/N	L3839

MARTIN[®] SPRING TENSIONER STANDARD

Tensioner P/N	38180
Belt Width	18-48 in.
Dual Tensioner P/N	38180-2
Belt Width	54-96 in.
Technical Data Sheet P/N	L3370-16

MARTIN[®] AIR TENSIONERS

Control Box P/N	36489
XHD Air Tensioner P/N	32135
Std./HD Air Tensioner P/N	37843
Std./HD Air Control Kit P/N	31772-AS
Control Panel w/CO ₂ P/N	38491-2
XHD Air Control Kit P/N	32181

MARTIN[®] ADJUSTABLE L BRACKET SPRING TENSIONER

Tensioner P/N	31291-SM
Belt Width	18-54 in.
Technical Data Sheet P/N	L3370-16

MARTIN[®] REVERSING MOUNT SPRING TENSIONER

Reversing Mount Tensioner P/N	33599
Reversing Cleaner Z Bracket P/N	31158-01
Reversing Hanger Mount Assembly P/N	33288
Belt Width	18-96 in.
Technical Data Sheet P/N	L3370-16

MARTIN[®] SPRING TENSIONER XHD

Tensioner P/N	38003
Belt Width	18-48 in.
Dual Tensioner P/N	38003-2
Belt Width	54+ in.
Technical Data Sheet P/N	L3370-16

MARTIN[®] MOUNTING BRACKETS

L Bracket P/N	33706
Flange Mount Bracket P/N	30537
Hanger Mount Assembly P/N	27382
Reversing Hanger Mount Assembly P/N	33288
Heavy Duty Hanger Mount Assembly P/N	34233-HD
Technical Data Sheet P/N	L3370-16

MARTIN[®] SHOCK MOUNT AIR PADDLE TENSIONER

Tensioner P/N	32745
Belt Width	18-54 in.
Dual Tensioner P/N	32745-2R
Belt Width	60-96 in.
Technical Data Sheet P/N	L3370-16

ACCESSORIES

MARTIN[®] INSPECTION DOORS

Steel Door P/N	CYA-XXXX
Rubber Door P/N	CYAR-XXXX
Extended-Height Steel Door P/N	CYAE-XXXX
Round Steel Door P/N	CYARD-XXXX
Technical Data Sheet P/N	L3432

MARTIN[®] PRESSURE ROLLER BRACKET

Brackets Pair w/Roller for DH2 P/N	32290-XXXX
Brackets Pair w/o Roller P/N	32290-XX
Bracket Assembly for SAF2™ & SQC2S™ P/N	34542-XX
Bracket Assembly for O2, H2O & DT2 P/N	37954-XXXX
Technical Data Sheet P/N	L3370-15

MARTIN[®] VIBRATING DRIBBLE CHUTE

Vibrating Dribble Chute P/N	31546
w/Overload Protection P/N	31546-OL
Dribble Sheet Liner P/N	31494XXXXXX
Technical Data Sheet P/N	L3370-14

MARTIN[®] CARRYBACK CAPTURE SYSTEM

Carryback Capture System P/N	CCSXXXXXXX
Belt Width	24-72 in.
Technical Data Sheet P/N	L3806

MARTIN[®] ROLL GEN™ SYSTEM

Roll Generator	RG1-010-XXPX
Roll Gen™ Power Supply	39413
Roll Gen™ Continuous Power Supply	contact for specs



AIRMATIC founded in 1944, is a woman-owned Industrial Distributor, with installation and maintenance capabilities, offering equipment, machinery, and shop supplies to the Industrial, Construction, Utility, Government, and Commercial Markets. Our products and services are sold through three business units:

The **MATERIALS MANAGEMENT GROUP** provides products and services to industries that convey, store, transport, and process powders and bulk solids from aggregates, cement, and chemicals to foods, grains, metals, power generation, and waste water treatment applications;

The **SERVICE GROUP** provides fabrication, installation, and maintenance services to improve bulk materials handling efficiency; mechanical clean-out services for silos and hoppers to eliminate material flow problems; and shop repair/rebuilding and modifications services of products sold by the Company.

The **TOOL GROUP** provides power tools, personal protective equipment, materials-handling equipment, shop equipment and MRO supplies used for production, fabrication, assembly, metal removal, maintenance, and storage in manufacturing, construction, utility, and commercial applications. Our Customers tell us that by choosing **AIRMATIC** to solve their problems, they gain increased productivity, decreased costs, and a safer, cleaner work environment.

The logo for MARTIN features the word "martin" in a bold, orange, italicized sans-serif font with a registered trademark symbol (®).

MARTIN ENGINEERING is the leading global supplier of system to make the handling of bulk materials cleaner, safer, and more productive. Since its founding in 1944, the company has grown dramatically through the development of solutions to help the solids-handling industries around the world. MARTIN ENGINEERING's success can be attributed to the development of practical, field-proven, cost-effective answers for "real life" problems. MARTIN Products are designed for tough industrial conditions; they are built to allow easy maintenance; they are engineered for simplicity, cleanliness, safety, and efficiency; they are personalized to meet each customer's unique requirements.

AIRMATIC

284 Three Tun Rd. Malvern, PA 19355
215.333.5600
infocenter@airmatic.com
airmatic.com